

EAT•N

Cutler-Hammer

**Disconnect Switches
Product Guide**

**Rotary Switches
Non-fused
Fused
Enclosed Rotary**

**Operating Mechanisms
Accessories**

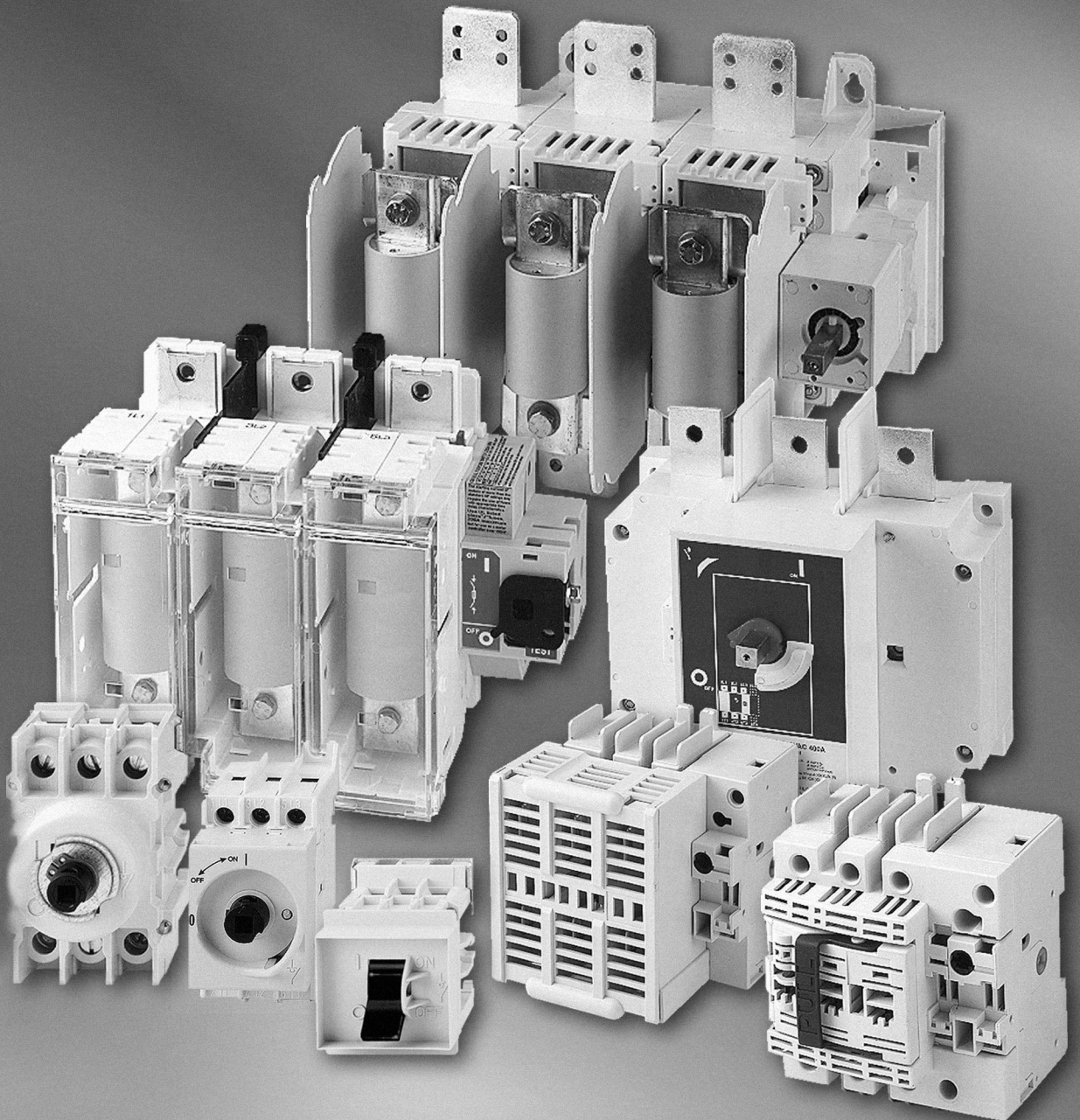

Manual Motor Disconnect Switches

Contents

<i>Description</i>	<i>Page</i>
Rotary Disconnect Switches C362/C363	
Product Description	2
Features, Benefits and Functions	2
Standards and Certifications	2
Options and Accessories	2
Product Selection	
C362 – Non-fused Switches R, W, C, V & S Frames	4
C363 – Fusible Switches, C,V, F Frame Switches	4
Handles and Shafts	5, 6
Accessories	7
Technical Data and Specifications R, W Frame	8
C-Frame	9
V-Frame	10 - 12
S-Frame	13
F-Frame	14
Handles	15
Technical Characteristics	16, 17
Enclosed Rotary Disconnect Switches	18 - 23
Product Selection	18
Dimensional Drawings	19 - 23
C361/C371 Operating Mechanisms	24 - 29
C361 Variable Depth Disconnects	24 - 25
C361 Fixed Depth Disconnects	26
C361 Accessories	27
C371 Fixed/Variable Depth Circuit Breakers	28 - 29

Product Description

Non-fused

- **R & W frame**, 30A – 80A, non-fusible 600V AC, suitable for use in equipment or machinery as a motor disconnect.
- **Manual motor controller suitable for motor disconnect**, horsepower and Amp rated, load break rated, meeting requirements of CSA C22.2 No 14 CEC rule 28-602 (3) (b) and UL508 "suitable for motor disconnect." 10 kVA short circuit rating when used in conjunction with Class J fusing.
- **C, V, & S Frame**, 30A - 1200A, non-fusible, 600V AC, rated 250 V DC inclusive to 600A. Suitable for use as motor or industrial control panel disconnects, horsepower and Amp rated, load break rated, meeting requirements of CSA C22.2 No 4 and UL98.

Fusible

- 30A - 800A fusible 600V AC, **C, V & F Frame**, rated 250 V DC inclusive to 400A. Suitable for use as motor or industrial control panel disconnect, suitable for use as a service entrance disconnect, horsepower and Amp rated, load break rated, meeting requirements of CSA C22.2 No 4 and UL98.

Features, Benefits and Functions

- Fusible and non-fusible
- Rotary or toggle operation (non-fused)
- Motor disconnects available approved to CEC rule 28-602(3)(b)
- Base mounting or DIN rail mounting
- Compact design to minimize panel space requirements
- Pistol type or selector type handles for through-the-door operation.
- Toggle type handle for internal panel mounting
- Variable depth – complete range of shafts that can be cut for specific enclosure depths
- Clear ON and OFF indication.
- Padlockable in the OFF position with up to three padlocks.
- Interlocked, defeatable handle available. Allows access by authorized personnel in the ON position.
- ON/OFF/TEST (3 position) handles allow testing of the control circuit auxiliaries without switching the main contacts.
- Optional N/O, N/C auxiliary contacts available
- Visible blade indication up to 200A (non-fused C & V frames)

- Line side shrouds standard on all ratings for C, S, V & F frames
- Load side finger shrouds standard on non-fusible 30-100A C & V frame and 30-60A fusible.
- Optional shrouds available for higher ratings of V, S & F frame
- Terminal lugs standard for C & V frame 30-100A non-fused and 30-60A fusible.

Standards and Certifications

R- W-Frames

- UL 508
- CSA C22.2 No 14 CEC rule 28-602(3)(b)
- IEC 60-947-3

C-, V-, S-, F-Frames

- UL 98
- CSA C22.2 # 4
- IEC 60-947-3
- CE

Options and Accessories

- Neutral modules.
- Auxiliary contacts.
- 4th pole modules.
- Protective earth modules.

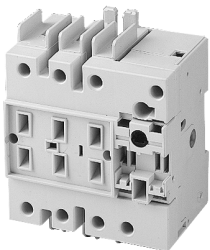

**C-Frame
Non-Fusible**

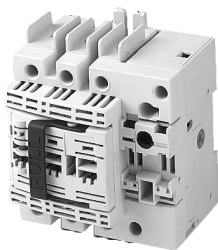

**C-Frame
Fusible**



**V-Frame
Fusible**

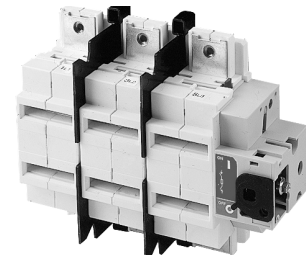

**V-Frame
Non-Fusible**



**R-Frame
Non-Fusible**



**W-Frame
Non-Fusible**

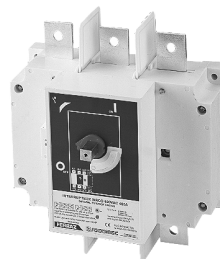

**S-Frame
Non-Fusible**

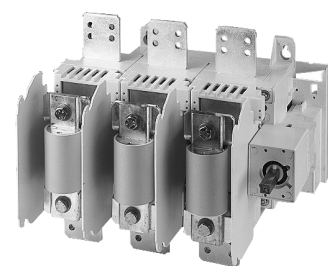

**F-Frame
Fusible**

NOTE: Photo does not represent proportional sizing between frame types

Padlocking

Handles can be padlocked in the OFF position with up to three padlocks.

For safety reasons, the door cannot be opened when the handle is padlocked.

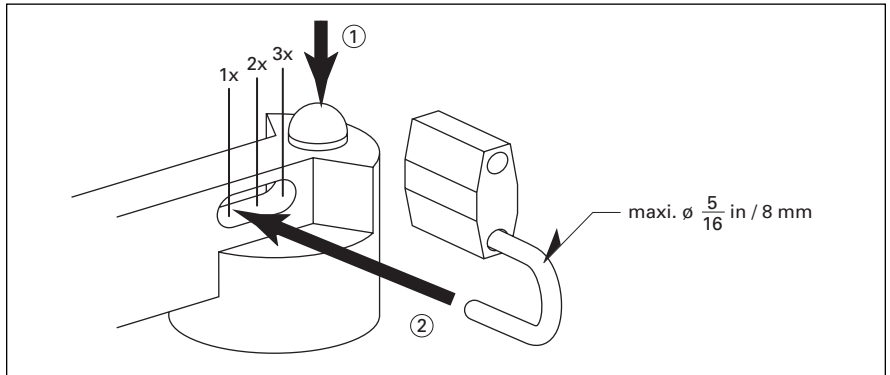

Figure 1. Padlocking Capability (Type G Pistol Handle is Shown)

Door Interlock in ON Position

The handles allow opening of the door in the OFF position only. In the ON position, the door cannot be opened.

This interlocking can however be bypassed by authorized personnel (defeater option on handle) for maintenance, testing or commissioning.

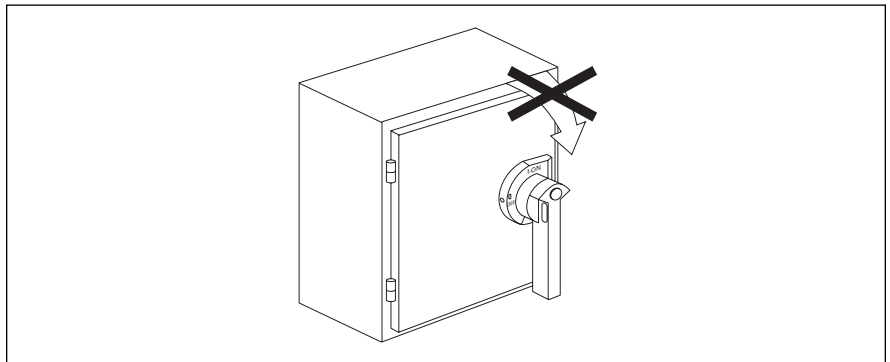

Figure 2. Door Interlocking

Defeater

The defeat function allows qualified personnel to bypass the door interlock when the switch is in the ON position by means of a tool.

This exclusive design is also available in a 4 and 4X rating.

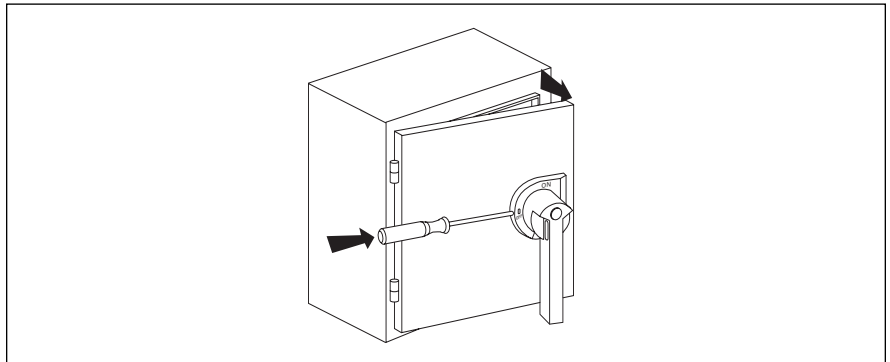

Figure 3. Interlocking Defeater

Toggle Option

Available for internal panel mounting.



**Toggle Operated Switch
(Shown with Optional Toggle Cover Plate
CWP3)**

Product Selection — Switches Catalogue Ordering Information

When ordering specify:

- Catalogue number of switch.
- Catalogue number of operating handle. Pages 5,6.
- Catalogue number of required shaft. Pages 5,6.
- Catalogue number of (optional) accessories. Page 7.
- For dimensional data. Pages 8-15.
- For technical data. Pages 16, 17.

Table 1. Non-Fusible Switches

Ampere Rating	Maximum 3-Phase ^① Horsepower Rating			Catalogue Number
	240V	480V	600V	

DIN Rail / Base Mounted Rotary Switch R-, W-Frame with Brass Collar

30	7.5	15	20	C362NR30MD
40	10	20	25	C362NR40MD
60	15	30	40	C362NW60MD
80	20	40	50	C362NW80MD

DIN Rail / Base Mounted Toggle Switch R-, W-Frame

30	7.5	15	20	C362TR30MD
40	10	20	25	C362TR40MD
60	15	30	40	C362TW60MD
80	20	40	50	C362TW80MD

DIN Rail / Base Mounted Rotary Switch C-Frame

30	7.5	15	20	C362UC30
----	-----	----	----	----------

Base Mounted Rotary Switch V-Frame

60	15	30	50	C362UV60
100	30	60	75	C362UV100
200	60	125	150	C362UV200

Base Mounted Rotary Switch S-Frame

400	125	250	350	C362US400
600	200	400	350	C362US600
800	250	500	500	C362US800
1000	250	500	500	C362US1000
1200	250	500	500	C362US1200

Note: Suffix "MD" indicates Manual Motor Controller suitable for Motor Disconnect meeting requirements of CSA C22.2 No.14 CEC rule 28-602(3)(b) and UL508 "suitable for motor disconnects".

^① For additional HP ratings refer to pages 16 and 17.

Table 2. Fusible Switches

Ampere Rating	Fuse Type 600V	Maximum 3-Phase ^① Horsepower Rating			Catalogue Number
		240V	480V	600V	

DIN Rail / Base Mounted Fusible Switch C-Frame

30	CC	7.5	15	20	C363UC30CT (CC)
30	J	7.5	15	20	C363UC30JT (J)

Base Mounted Fusible Switch V-Frame

30	C	7.5	15	20	C363UV30C
30	J	7.5	15	20	C363UV30J
60	J	15	30	50	C363UV60J
100	J	30	60	75	C363UV100J
200	J	60	125	150	C363UV200J
400	J	125	250	350	C363UV400J
30	C	7.5	15	20	C363UV30CT
30	J	7.5	15	20	C363UV30JT
60	J	15	30	50	C363UV60JT
100	J	30	60	75	C363UV100JT
200	J	60	125	150	C363UV200JT
400	J	125	250	350	C363UV400JT







Base Mounted Fusible Switch F-Frame

600	J	250	500	500	C363UF600J
800	L	250	500	500	C363UF800L

Note: "T" suffix denotes test position is provided. Test handle is required for test function.





Product Selection — Handles and Shafts

Table 5. Handles and Shafts

								
Black Selector Handle		Red/Yellow Selector Handle		Selector Shafts				
NEMA Rating	Defeatable	Padlockable	Color	Operation	IEC Type	Dimensions		Catalogue Number
						Inches	mm	
Selector Handle for Type CSSA __ Shaft and R- and W-Frames or CSCSA __ Shaft and C-Frames								
1	No	No	Black	ON/OFF	IP54	①	—	CSBR5
1, 3R, 12	No	Yes	Red/Yellow	ON/OFF, I/O	IP65	—	—	CSYR6
1, 3R, 12	No	Yes	Black	ON/OFF, I/O	IP65	—	—	CSBR6
Rotary Switch Selector Shaft 5 x 5 mm (For Selector Handle and R- and W-Frames)						2.2	55	CSSA055
						4.3	110	CSSA110
						5.9	150	CSSA150
						7.1	180	CSSA180
						7.9	200	CSSA200
						11.8	305	CSSA300
Rotary Switch Selector Shaft 5 x 5 mm (For Selector Handle and C-Frames)						4.7	120	CSCSA120
						7.9	200	CSCSA200
						11.8	300	CSCSA320
						15.7	400	CSCSA400
								
Black Pistol Handle (Type D)		Red/Yellow Pistol Handle (Type D)		Type D Pistol Shafts				
NEMA Rating	Defeatable	Padlockable	Color	Operation	IEC Type	Dimensions		Catalogue Number
						Inches	mm	
Pistol Handle Type D (For use with CPDSA & CPDCA Shafts for R- and W-Frames and C-Frame.)								
1, 3R, 12	No	Yes	Black	ON/OFF, I/O	IP54	①	—	CPBR5N
1, 3R, 12	No	Yes	Red/Yellow	ON/OFF, I/O	IP54	—	—	CPYR5N
1, 3R, 12	Yes	Yes	Black	ON/OFF, I/O	IP54	—	—	CPBR5D
1, 3R, 12	Yes	Yes	Red/Yellow	ON/OFF, I/O	IP54	—	—	CPYR5D
Type D Shafts 5 x 5 mm (For use with Type D Pistol Handles and R- and W-Frames)						4.7	120	CPDSA120
						7.9	200	CPDSA200
						12.6	320	CPDSA320
						15.7	400	CPDSA400
Type D Shafts 5 x 5 mm (For use with Type D Pistol Handles and C-Frames)						4.7	120	CPDCA120
						7.9	200	CPDCA200
						12.6	320	CPDCA320
						15.7	400	CPDCA400
Direct Handle R-, W-Frames (For Direct Mounting — No Separate Shaft Required)								
1, 3R, 12	No	Yes	Black	ON/OFF	IP54	①	—	CDRR3
1, 3R, 12	No	Yes	Black	ON/OFF	IP54	—	—	CDRW3
1, 3R, 12	No	Yes	Black	ON/OFF	IP54	—	—	CDRR4

① Please refer to Page 15.

Table 5. Handles and Shafts (Continued)

NEMA Rating	Defeatable	Padlockable	Color	Operation	IEC Type	Dimensions		Catalogue Number
						Inches	mm	
  								
<p>Black Pistol Handle (Type G) Red/Yellow Pistol Handle (Type G) Type G Pistol Shafts</p>								
Pistol Handle Type G (For use with R-, W- and C-Frames with 5 x 5 shaft and V-Frame below 100A with 10 x 10 shaft)								
1, 3R, 12	Yes	Yes	Black	ON/OFF, I/O	IP54	①	①	CPBR5
1, 3R, 12	Yes	Yes	Red/Yellow	ON/OFF, I/O	IP54	①	①	CPYR5
1, 3R, 12, 4, 4X	Yes	Yes	Black	ON/OFF, I/O	IP65	①	①	CPBW6
1, 3R, 12, 4, 4X	Yes	Yes	Red/Yellow-Black	ON/OFF, I/O	IP65	①	①	CPYW6
1, 3R, 12, 4, 4X	Yes	Yes	Black	TEST/ON/OFF	IP65	①	①	CPBW6T
1, 3R, 12, 4, 4X	Yes	Yes	Red/Yellow	TEST/ON/OFF	IP65	①	①	CPYW6T
Long Pistol Handle Type GL (For use with V-Frame 100A and above with 10 x 10 shaft)								
1, 3R, 12	Yes	Yes	Black	ON/OFF, I/O	IP54	①	①	CPBVR5
1, 3R, 12	Yes	Yes	Red/Yellow	ON/OFF, I/O	IP54	①	①	CPYVR5
1, 3R, 12, 4, 4X	Yes	Yes	Black	ON/OFF, I/O	IP65	①	①	CPBVW6
1, 3R, 12, 4, 4X	Yes	Yes	Red/Yellow	ON/OFF, I/O	IP65	①	①	CPYVW6
1, 3R, 12	Yes	Yes	Black	TEST/ON/OFF	IP65	①	①	CPBVW6T
1, 3R, 12	Yes	Yes	Red/Yellow	TEST/ON/OFF	IP65	①	①	CPYVW6T
Type G Shafts 5 x 5 mm (For use with Type G Pistol Handle and R- and W-Frames)								
						4.7	120	CPGSA120
						7.9	200	CPGSA200
						12.6	320	CPGSA320
						15.7	400	CPGSA400
Type G Shafts 5 x 5 mm (For use with Type G Pistol Handle and C-Frames)								
						4.7	120	CPGCSA120
						7.9	200	CPGCSA200
						12.6	320	CPGCSA320
						15.7	400	CPGCSA400
Type G Shafts 10 x 10 mm (For use with Type G and GL Pistol Handles and V-Frames)								
						7.9	200	CPGSB200
						12.6	320	CPGSB320
						15.7	400	CPGSB400
								
Pistol Handle (Type H)								
NEMA Rating	Defeatable	Padlockable	Color	Operation	IEC Type	Dimensions		Catalogue Number
						Inches	mm	
Pistol Handle Type H (For use with S-Frames with 15 x 15 shaft)								
1, 3R, 4, 4X, 12	Yes	Yes	Black	ON/OFF, I/O	IP65	①	—	CPBSW6D
1, 3R, 4, 4X, 12	Yes	Yes	Red/Yellow	ON/OFF, I/O	IP65	—	—	CPYSW6D
1, 3R, 4, 4X, 12	No	Yes	Black	ON/OFF, I/O	IP65	—	—	CPBSW6N
1, 3R, 4, 4X, 12	No	Yes	Red/Yellow	ON/OFF, I/O	IP65	—	—	CPYSW6N
Pistol Handle Type H (For use with F-Frames with 15 x 15 shaft)								
1, 3R, 4, 4X, 12	Yes	Yes	Black	ON/OFF, I/O	IP65	①	—	CPBFW6D
1, 3R, 4, 4X, 12	Yes	Yes	Red/Yellow	ON/OFF, I/O	IP65	—	—	CPYFW6D
1, 3R, 4, 4X, 12	No	Yes	Black	ON/OFF, I/O	IP65	—	—	CPBFW6N
1, 3R, 4, 4X, 12	No	Yes	Red/Yellow	ON/OFF, I/O	IP65	—	—	CPYFW6N
Type H Shafts 15 x 15 mm (For use with Type H Pistol Handles and S- and F-Frames)								
						7.9	200	CPHSC200
						15.7	400	CPHSC400

① Please refer to Page 15.

Product Selection — Accessories

Table 3. Accessories — R, W-Frames

Description		Catalogue Number
Toggle Cover Plates	For use with C362TR30MD & 40MD For use with C362TW60MD & 80MD	CRP3 CWP3
Auxiliary Contacts Kit (Holder and Contact)	1NO for R -Frame (30 & 40 Amps) 1NO for W -Frame (60 & 80 Amps)	CRAC3 ① CWAC3 ①
Auxiliary Contacts (Additional Contacts)	1NO - for R, W -Frame 1NC - for R, W -Frame	CRAB ① CRAA ①
Extension Support		C362SS1
Replacement Brass Collar R and W -Frames		CRC
Door Mounting Kit R and W -Frames Rotary Switches		CTRFC

① The mechanism is reversed on these contacts.

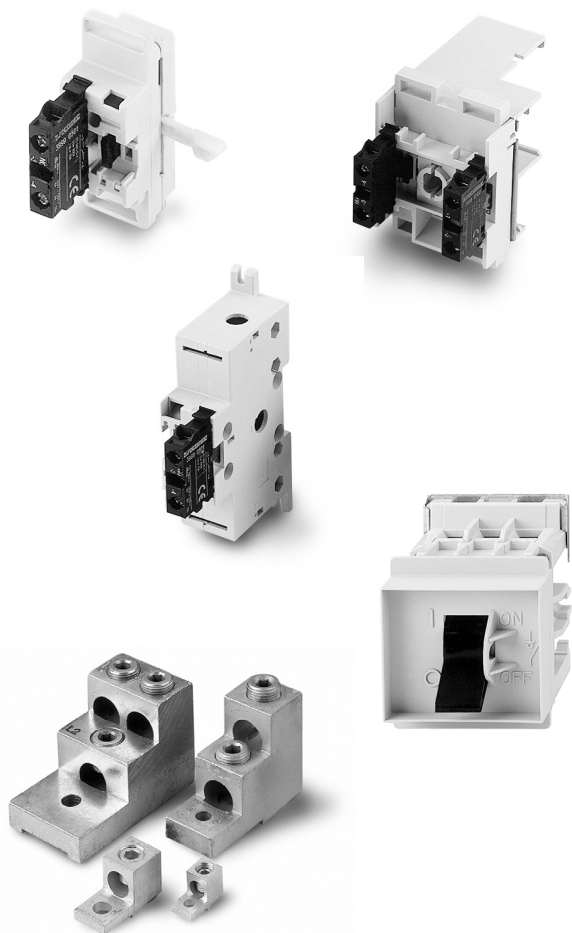

Table 4. Accessories — C, S, V, F-Frames

Description		Catalogue Number
Auxiliary Contact Holders	C -Frame (for 5-8) ② V -Frame (for 1-8) S -Frame (for 1-4)	CUCU CUVU CUSU
Auxiliary Contacts	1 NO, Type U aux. contact for C, V, S Frames 1 NC, Type U aux. contact for C, V, S Frames	CUSAA ③ CUSAB ③
	1 NO/NC, Type S aux. contact, for 30A-400A V -Frames 2 NO/NC, Type S aux. contact, for 30A-400A V -Frames	CUVAC ④ CUVAD ④
	1 NO/NC, Type ST aux. contact for Fusible, 30A-400A V -Frame w/Test 2 NO/NC, Type ST aux. contact for Fusible, 30A-400A V -Frame w/Test	CUVXC ④ CUVXD ④
	1 NO/NC, Type MS aux. contact, for Fusible 600A & 800A F -Frame 2 NO/NC, Type MS aux. contact, for Fusible 600A & 800A F -Frame	CUFAC ⑤ CUFAD ⑤
Load-Side Terminal Shrouds for Non-Fusible V - and S -Frames ③	3-Pole, V -Frame (200A) 3-Pole, for Non-Fusible S -Frame (400 - 600A) 3-Pole, for Non-Fusible S -Frame (800 - 1200A)	CUV200T CUS600T CUS1200T
Load-Side Terminal Shrouds for Fusible V - and F -Frames ④	3-Pole, for Fusible V -Frame (100A) 3-Pole, V -Frame (200A) 3-Pole, for Fusible V -Frame (400A) 3-Pole, for Fusible F -Frame (600 & 800A)	CUV100T CUV200T CUV400T CUF800T
Shorting Links for 3 Poles Fusible, V - and F -Frames	V -Frame (60A) V -Frame (100A) V -Frame (200A) V -Frame (400A) F -Frame (600 & 800A)	CUV60SL ⑥ CUV100SL ⑥ CUV200SL ⑥ CUV400SL ⑥ CUF800SL ⑥
Terminal Lugs for Non-Fusible and Fusible V -, S - and F -Frames, for line or load side ⑦	1 Wire/lug, Wire Size #12-2/0, for Fusible V -Frame (100A) 1 Wire/lug, Wire Size #6-3/0, for V -Frame (200A) 2 Wires/lug, Wire Size #2-600, MCM for V, S - & F -Frames (400 & 600A) 3 Wires/lug, Wire Size #2-600, MCM for S - & F -Frames (800-1000A) 2 Wires/lug, Wire Size# 2-600, MCM S -Frame (1200A)	CUV100LN ⑦ CUV200LN ⑦ CUS600LN ⑦ CUS1000LN ⑦ CUS1200LN ⑧

- ② **C**-Frames (standard product) hold 1-4 Auxiliary Contacts without additional holder.
- ③ Line-side terminal shrouds provided as standard on all ratings. Load-side terminal shrouds standard on non-fused **C** and **V**-Frames up through 100A.
- ④ Line-side terminal shrouds provided as standard on all ratings. Load-side terminal shrouds standard on fusible switches up through 60A.
- ⑤ Kit of 3.
- ⑥ Terminal lugs provided as standard on Non-Fusible up through 100A and Fusible up through 60A.
- ⑦ Kit of 3.
- ⑧ Kit of 6.
- ⑨ Aux contacts are "Early Break/Late Make."
- ⑩ Side mounted aux contact do not have "Early Break" - they open and close at the same time as the switch.

Dimensions, Weights and Ratings

Dimensions, weights and ratings given in this Product Guide are **approximate and should not be used for construction purposes**. Drawings containing exact dimensions are available upon request. All listed product specifications and ratings are subject to change without notice. Photographs are representative of production units.

Technical Data and Specifications

Dimensions in Inches (mm)

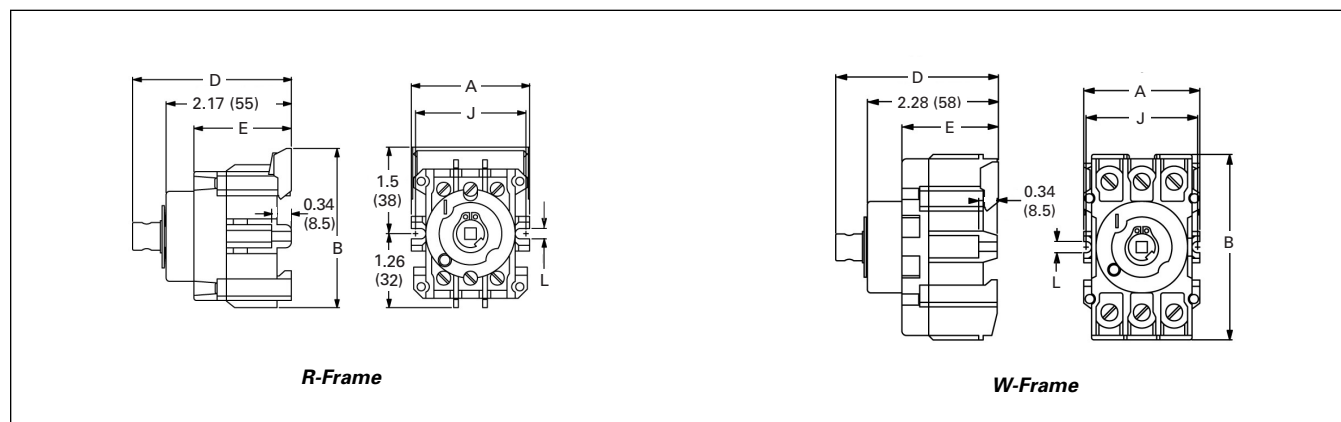

Figure 4. R- and W-Frames

Table 6. R- and W-Frames — Dimensions in Inches (mm)

Frame	Ampere Rating	A	B	D	E	J	K	L
R	30 – 40	2.00 (50.8)	2.75 (69.9)	2.68 (68.1)	1.65 (41.9)	1.89 (48.0)	—	.17 (4.3)
W	60 – 125	2.09 (53.1)	3.35 (85.1)	2.88 (73.2)	1.69 (42.9)	2.05 (52.1)	—	.17 (4.3)

Note: Frame is designated by the sixth character in the switch Catalogue number.

Dimensions in Inches (mm)

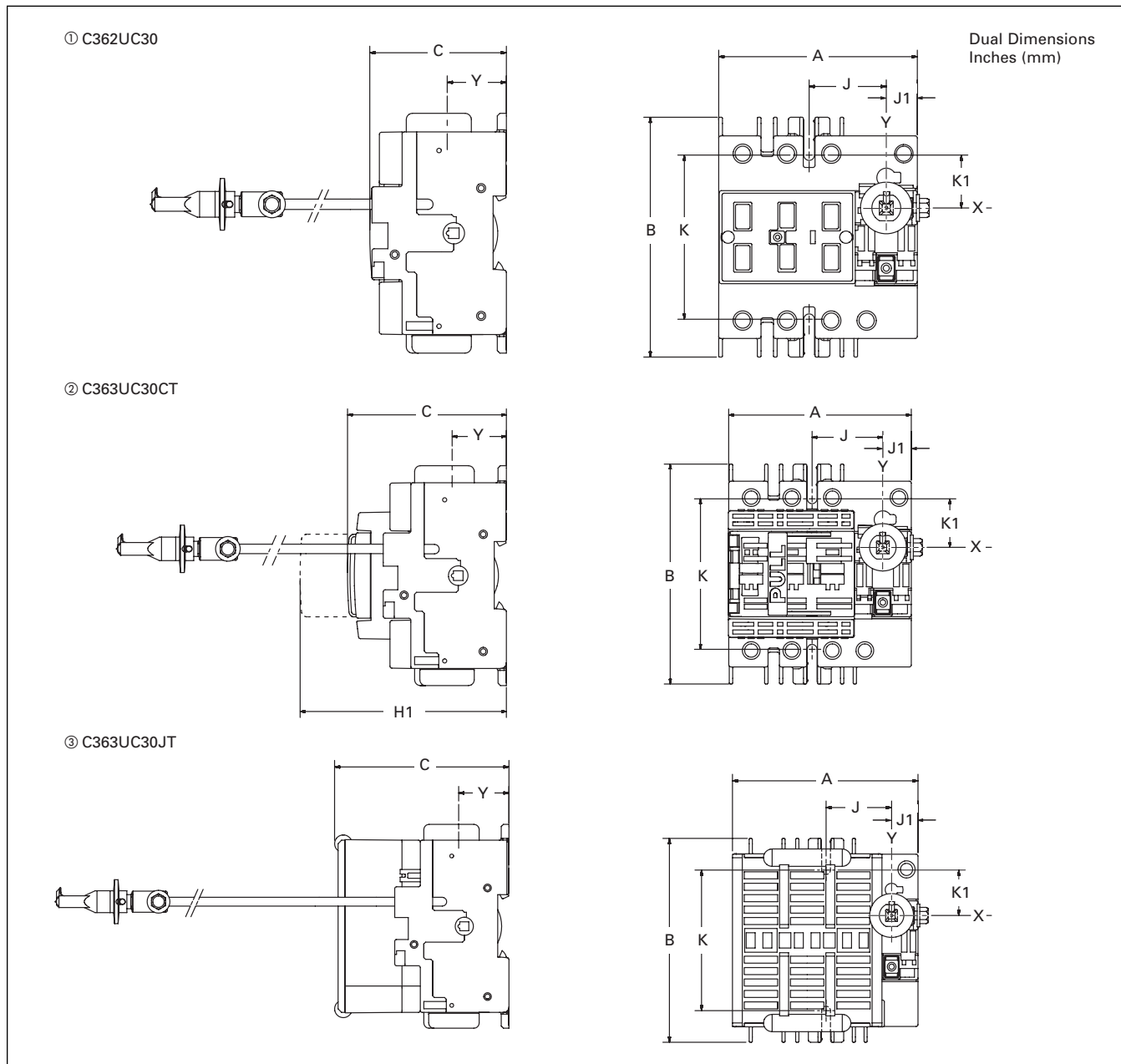

Figure 5. C-Frames

Table 7. Dimensions in Inches (mm)

Description	A	B	C	H	H1	H2	H3	J	J1	K	K1	Y
3-Pole ①	3.78 (96.0)	4.56 (115.8)	2.59 (65.8)	—	—	—	—	1.47 (37.3)	.59 (15.0)	3.13 (79.5)	1.00 (25.4)	1.12 (28.4)
3-Pole ②	3.78 (96.0)	4.56 (115.8)	3.28 (83.3)	—	5.19 (131.8)	—	—	1.47 (37.3)	.59 (15.0)	3.13 (79.5)	1.00 (25.4)	1.12 (28.4)
3-Pole ③	4.13 (104.9)	4.56 (115.8)	3.89 (98.8)	—	—	—	—	1.47 (37.3)	.59 (15.0)	3.30 (83.8)	1.00 (25.4)	1.12 (28.4)

Dimensions in Inches (mm)

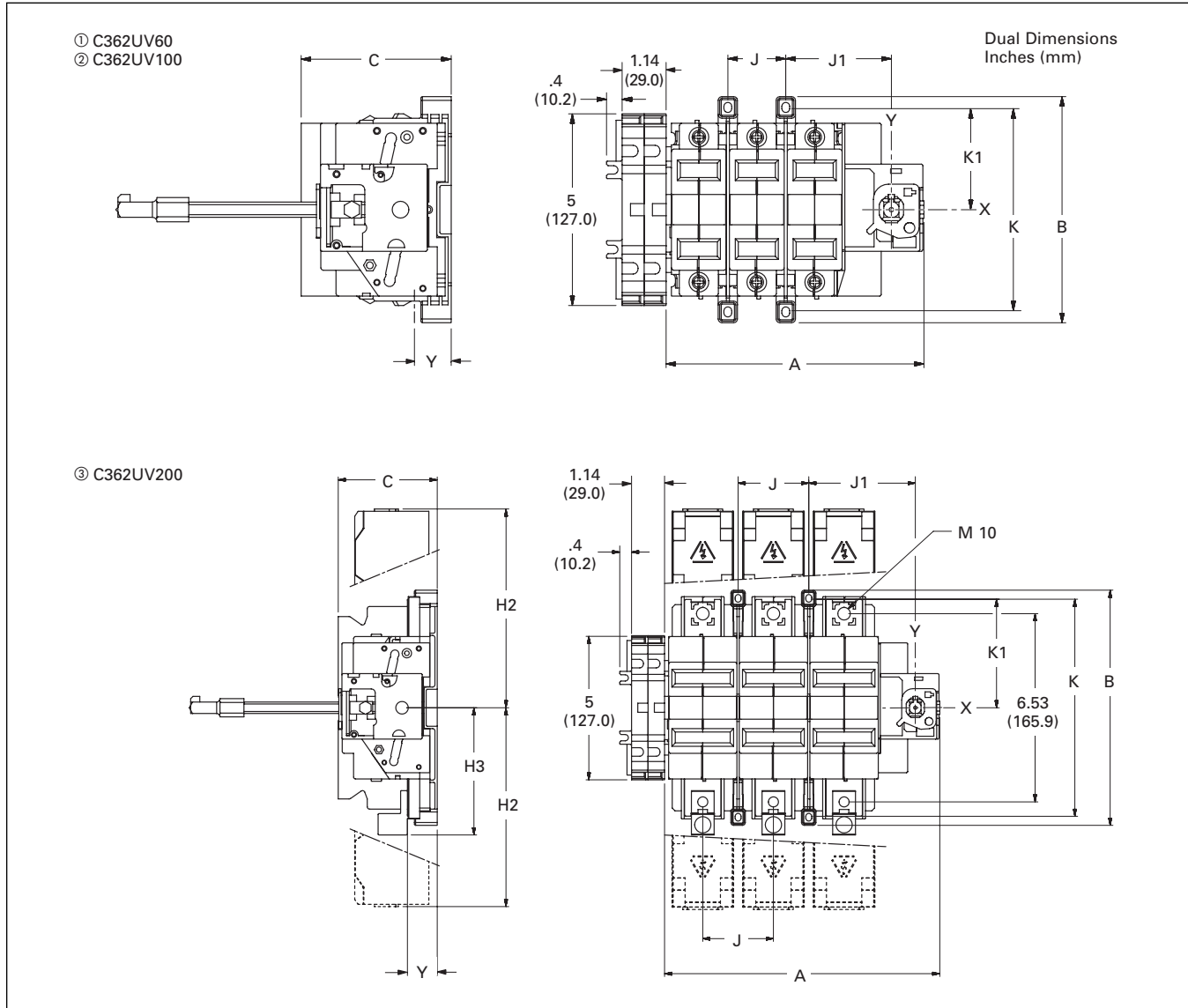

Figure 6. Non-Fusible V-Frames

Table 8. Dimensions in Inches (mm)

Description	A	B	C	H	H1	H2	H3	J	J1	K	K1	Y
3-Pole ①	6.69 (169.9)	5.87 (149.1)	3.89 (98.8)	—	—	—	—	1.50 (38.1)	2.75 (69.9)	5.25 (133.4)	2.63 (66.8)	.95 (24.1)
3-Pole ②	6.69 (169.9)	5.87 (149.1)	3.89 (98.8)	—	—	—	—	1.50 (38.1)	2.75 (69.9)	5.25 (133.4)	2.63 (66.8)	.95 (24.1)
3-Pole ③	9.52 (241.8)	8.13 (206.5)	3.42 (86.9)	—	—	6.87 (174.5)	4.39 (111.5)	2.44 (62.0)	3.68 (93.5)	7.50 (190.5)	3.74 (95.0)	.95 (24.1)

Dimensions in Inches (mm)

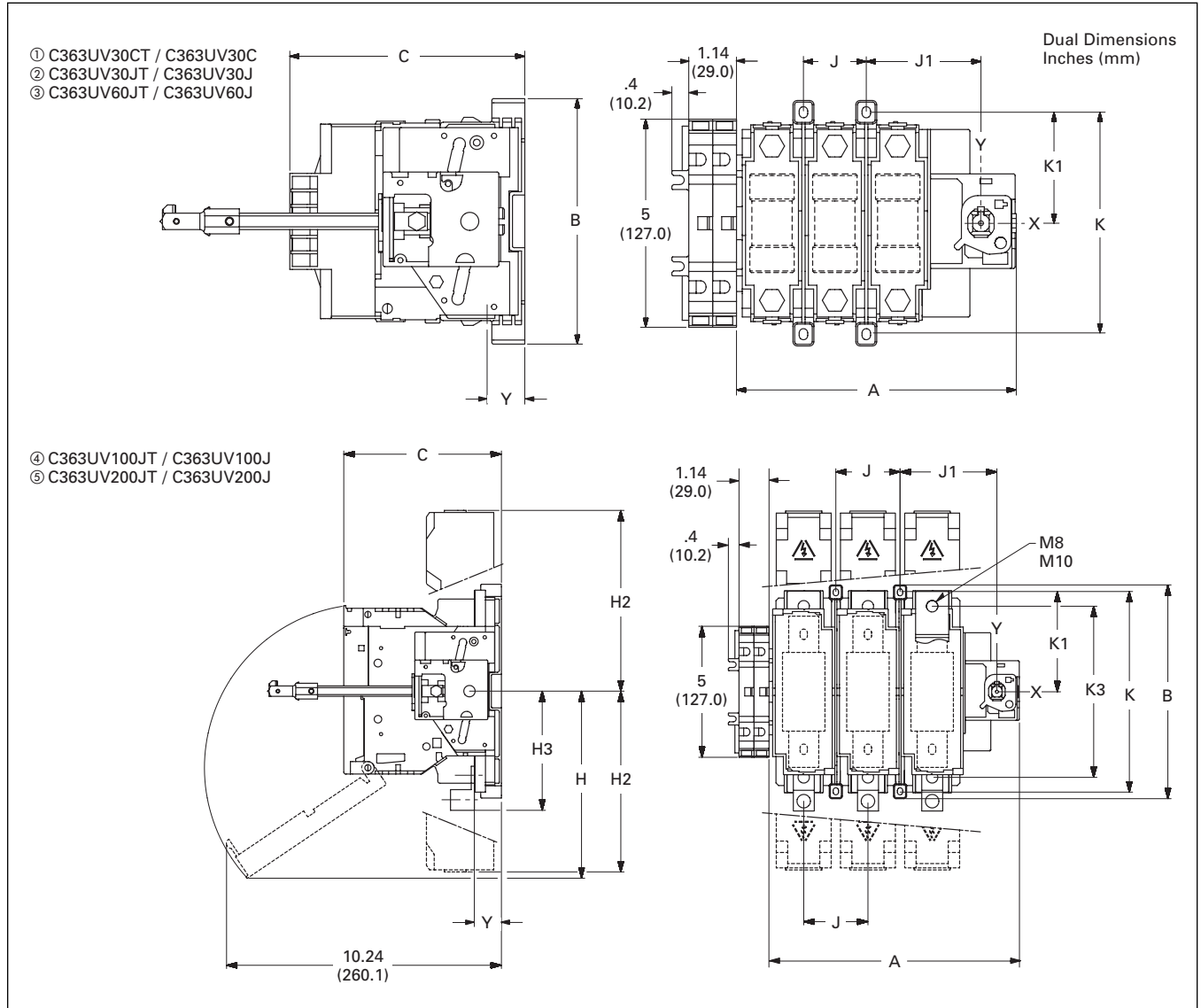

Figure 7. Fusible V-Frames

Table 9. Dimensions in Inches (mm)

Description	A	B	C	H	H2	H3	J	J1	K	K1	K3	Y
3-Pole ①	5.63 (143.0)	5.87 (149.1)	3.89 (98.8)	—	—	—	1.14 (29.0)	2.38 (60.5)	5.31 (134.9)	2.63 (66.8)	—	1.21 (30.7)
3-Pole ②	6.72 (170.7)	5.87 (149.1)	5.62 (142.7)	—	—	—	1.50 (38.1)	2.75 (69.9)	5.31 (134.9)	2.63 (66.8)	—	.95 (24.1)
3-Pole ③	6.72 (170.7)	5.87 (149.1)	5.62 (142.7)	—	—	—	1.50 (38.1)	2.75 (69.9)	5.31 (134.9)	2.63 (66.8)	—	.95 (24.1)
3-Pole ④	8.26 (209.8)	7.19 (182.6)	5.63 (143.0)	4.06 (103.1)	5.27 (133.9)	3.66 (93.0)	2.05 (52.1)	3.28 (83.3)	6.61 (167.9)	3.28 (83.3)	5.55 (141.0)	1.00 (25.4)
3-Pole ⑤	9.44 (239.8)	8.13 (206.5)	6.00 (152.4)	7.27 (184.7)	6.87 (174.5)	4.79 (121.7)	2.44 (62.0)	3.68 (93.5)	7.56 (192.0)	3.75 (95.3)	6.53 (165.9)	1.03 (26.2)

Dimensions in Inches (mm)

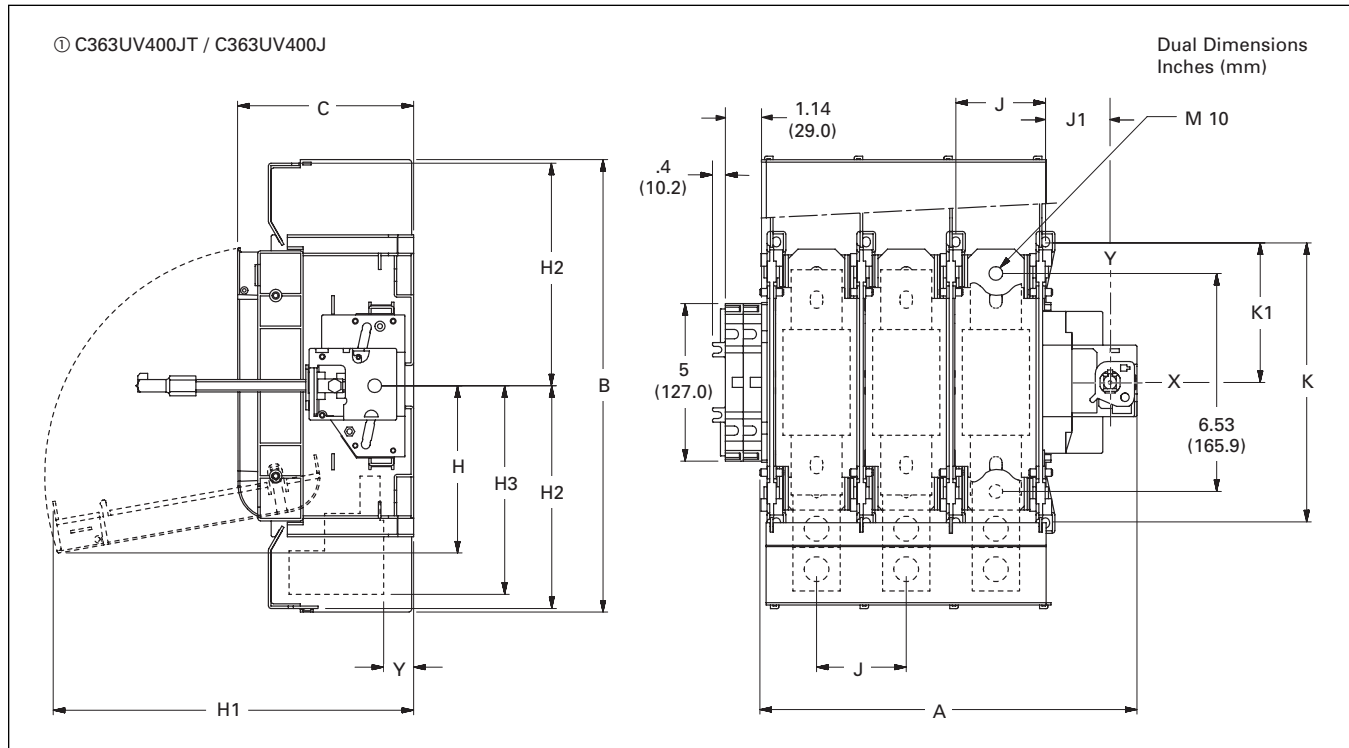

Figure 8. Fusible V-Frames (Continued)

Table 10. Dimensions in Inches (mm)

Description	A	B	C	H	H1	H2	H3	J	J1	K	K1	Y
3-Pole ①	11.93 (303.0)	14.31 (363.5)	5.56 (141.2)	5.28 (134.1)	11.41 (289.8)	7.04 (178.8)	6.59 (167.4)	2.84 (72.1)	2.04 (51.8)	8.83 (224.3)	4.41 (112.0)	1.06 (26.9)

Dimensions in Inches (mm)

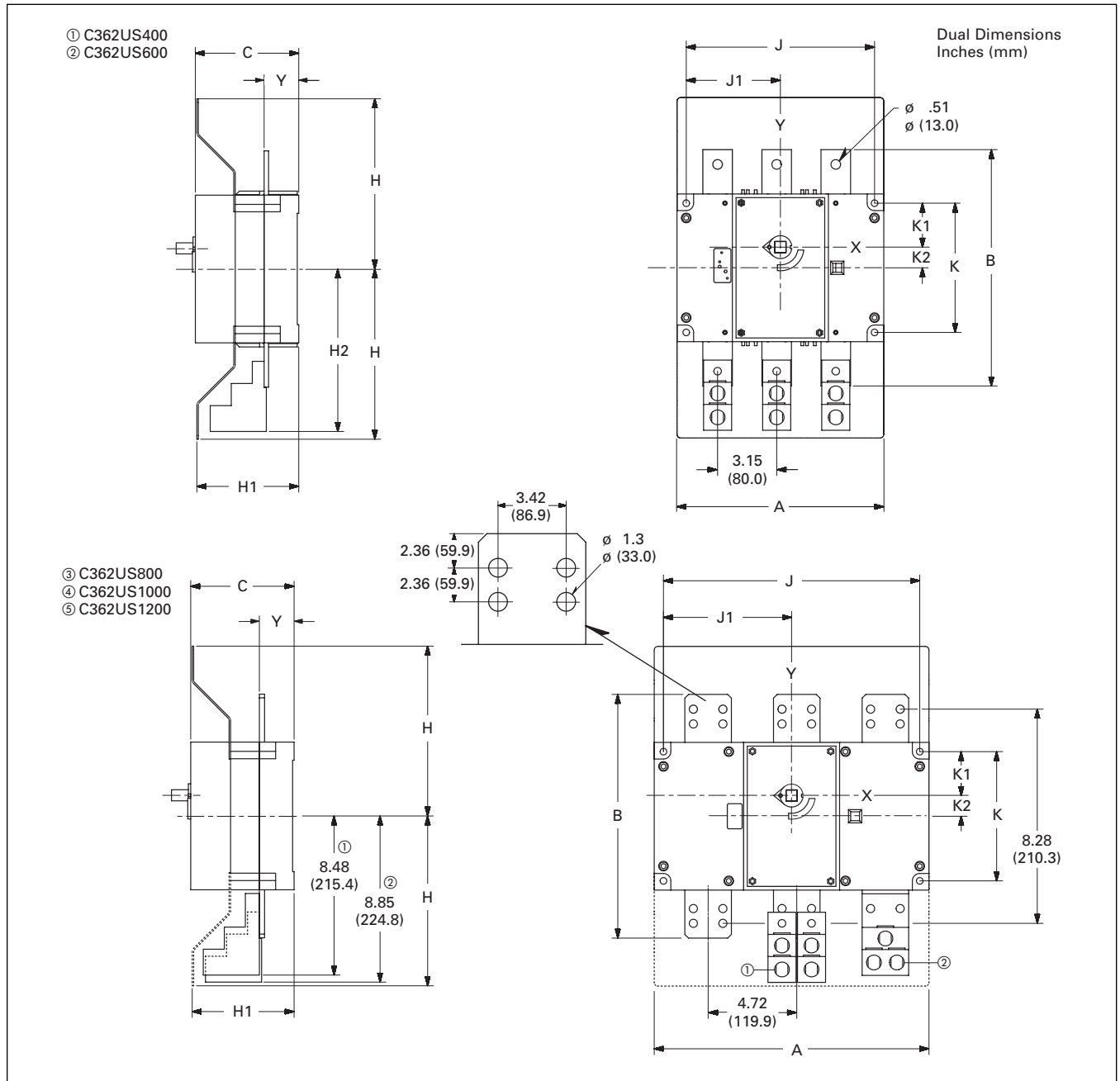

Figure 9. Non-Fusible S-Frames

Table 11. Dimensions in Inches (mm)

Description	A	B	C	H	H1	H2	J	J1	K	K1	K2	Y
3-Pole ①②	11.02 (279.9)	12.60 (320.0)	5.51 (140.0)	9.05 (229.9)	5.43 (137.9)	8.66 (220.0)	11.04 (280.4)	5.00 (127.0)	6.88 (174.8)	2.34 (59.4)	1.10 (27.9)	1.85 (47.0)
3-Pole ③④⑤	14.64 (371.9)	13.00 (330.2)	5.51 (140.0)	9.05 (229.9)	5.43 (137.9)	—	13.66 (347.0)	6.83 (173.5)	6.88 (174.8)	2.34 (59.4)	1.10 (27.9)	1.85 (47.0)

① C362US1200 when used with optional terminal lugs CUS1200LN.

② C362US800 and C362US1000 and when used with optional terminal lugs CUS1000LN.

Dimensions in Inches (mm)

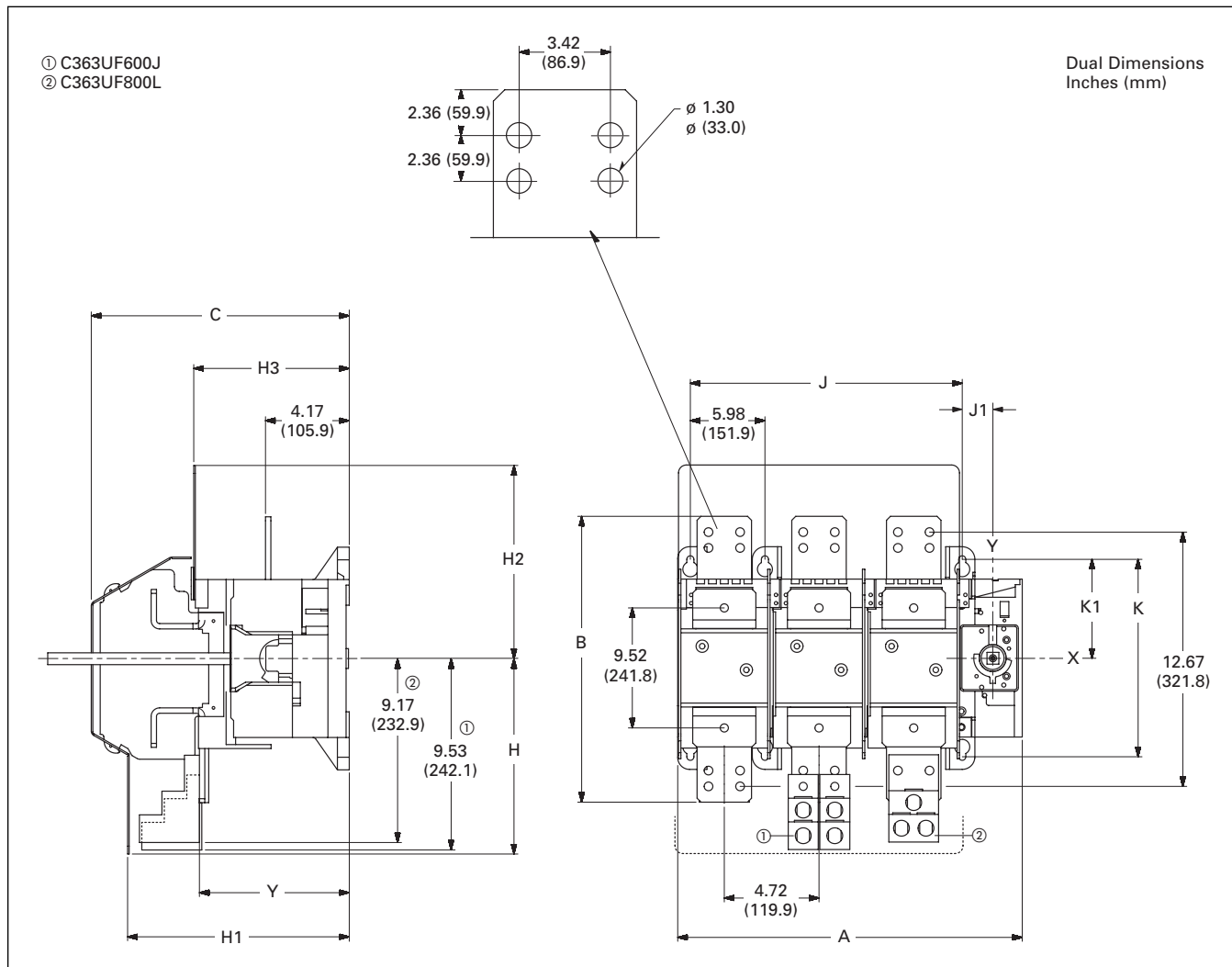

Figure 10. Fusible F-Frames

Table 12. Dimensions in Inches (mm)

Description	A	B	C	H	H1	H2	H3	J	J1	K	K1	Y
3-Pole ①②	17.18 (436.4)	14.25 (362.0)	12.87 (326.9)	9.74 (247.4)	11.06 (280.9)	8.66 (220.0)	7.75 (196.9)	13.58 (345.0)	1.51 (38.4)	9.84 (250.0)	4.92 (125.0)	7.48 (190.0)

① C363UF800L when used with optional terminal lugs CUS1000LN.

② C363UF600J when used with optional terminal lugs CUS600LN.

Handles — Dimensions in Inches (mm)

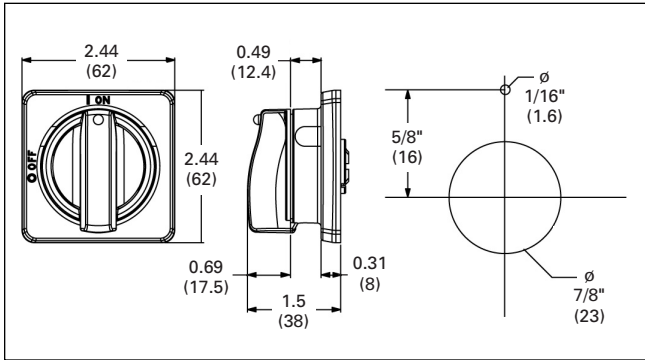

Figure 11. Selector Handle

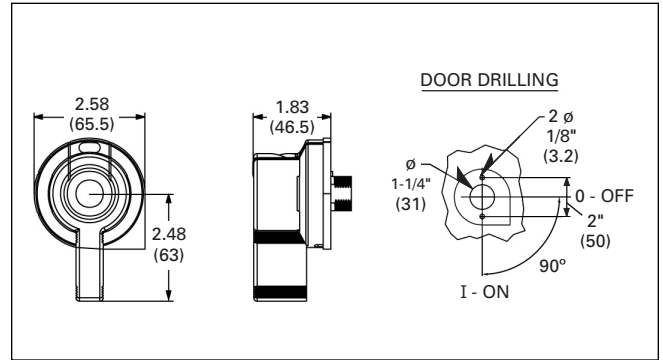

Figure 14. Pistol Handle — Type D

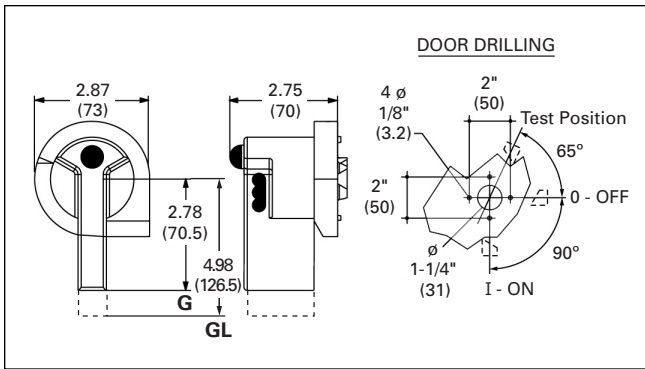

Figure 12. Pistol Handle — Type G and Type GL

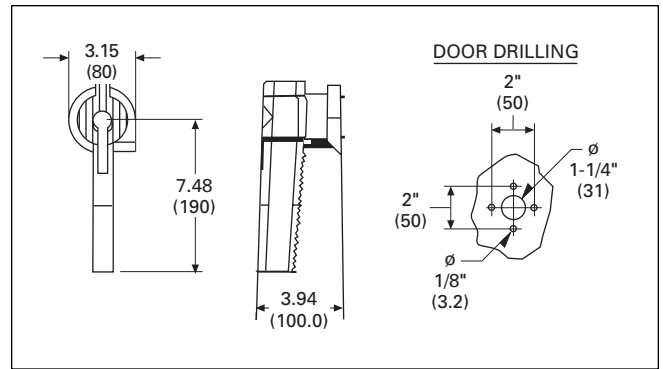

Figure 15. Pistol Handle — Type H

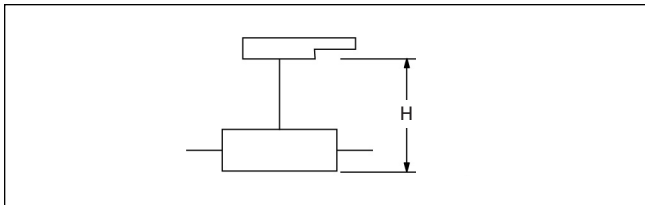

Figure 13. Mounting Depth

Table 13. Mounting Depth — Dimensions in Inches (mm)

Frame	Handle Type			
	Selector Handle	Pistol Handle	Pistol Handle	Pistol Handle
R	3.00 (76)	3.76 (96)	3.78 (96)	—
W	3.27 (83)	3.94 (100)	3.94 (100)	—
C (CC or Non-fusible)	3.94 (100)	4.13 (105)	4.13 (105)	—
C (J-Class Fuse)	—	5.91 (150)	5.12 (130)	—
V (30A CC or Non-Fusible)	—	—	3.94 (100)	—
V (30A J – 60A J)	—	—	6.10 (155)	—
V (60A – 200A Non-Fusible)	—	—	4.53 (115)	—
V (100A J – 200A J)	—	—	6.50 (165)	—
V (400A J)	—	—	6.89 (175)	—
S (400A – 600A)	—	—	—	8.35 (212)
S (800A – 1200A)	—	—	—	8.35 (212)
F (600A – 800A J)	—	—	—	16.38 (416)

Table 14. CSA Technical Characteristics

Description	R-Frame				W-Frame	
	Catalogue Number				Catalogue Number	
	C362NR30MD /C362TR30MD	C362NR40MD /C362TR40MD	C362NW60MD /C362TW60MD	C362NW80MD /C362TW80MD		
Rating Ampere	30A	40A	60A	80A		
CSA C22.2#14/CEC Rule 28-602/ (3)(b)	CSA	CSA	CSA	CSA		
Short Circuit Rating kA with Fuses	10	10	10	10		
Fuse Class	J	J	J	J		
Fuse Rating (A)	60	60	100	100		
Maximum CSA Horsepower Ratings (3-Phase)	120V AC	2	3	5	7.5	
	208V AC	5	7.5	10	15	
	220 – 240V AC	7.5	10	15	20	
	440 – 480V AC	15	20	30	40	
	600V AC	20	25	40	50	
Maximum CSA Horsepower Ratings (1-Phase)	120V AC	1.5	2	2	3	
	208V AC	2	3	5	7.5	
	240V AC	3	3	7.5	10	
	480V AC	7.5	7.5	15	20	
	600V AC	10	10	20	30	
Electrical Endurance	(Operation Cycles)	6000	6000	6000	6000	
Mechanical Endurance	(Operation Cycles)	6000	6000	6000	6000	
Terminal Lugs	Wire Size	#14 – #4	#14 – #4	#14 – #1	#14 – #1	
	Wire Type	Cu	Cu	Cu	Cu	
Weight in Lbs. (kg)		.44 (.20)	.44 (.20)	.66 (.30)	.66 (.30)	

Table 15. CSA/UL Technical Characteristics C, V, S & F Frame Non-Fused and Fusible

Catalogue Number	C Frame	V Frame	V Frame	V Frame	V Frame	S/V Frame	S/F Frame	S/F Frame	S Frame	S Frame	
	C362UC30 C362UC30CT C363UC30JT	C363UV30C C363UV30J C363UV30CT C363UV30JT	C362UV60 C363UV60J C363UV60JT	C362UV100 C363UV100J C363UV100JT	C362UV200 C363UV200J C363UV200JT	C362US400 C363UV400J C363UV400JT	C362US600 C363UF600J	C362US800 C363UF800L			
Rating Ampere	30	30	60	100	200	400	600	800	1000	1200	
CSA C22.2 #4/UL98	CSA/UL	CSA/UL	CSA/UL	CSA/UL	CSA/UL	CSA/UL	CSA/UL	CSA/UL	CSA/UL	CSA/UL	
Short Circuit Rating kA with Fuses	50	CC-100 J-200	200	200	200	200	200	100/200 ⑤	100	100	
Fuse Class	CC / J	CC / J	J	J	J	J	J	L	L	L	
Fuse Rating (A)	30	30	60	100	200	400	600	800	1000	1200	
Maximum UL Horsepower (3-Phase)	240V AC	7.5	7.5	15	30	60	125	200	250	250	
	480V AC	15	15	30	60	125	250	400	500	500	
	600V AC	20	20	50	75	150	350	350	500	500	
	DC 125V	3 ①	3 ①	3 ①	7.5 ①	15 ①	20 ①	20 ①④	—	—	—
	DC 250V	5 ①	5 ①	10 ②	20 ②	40 ②	50 ②	50 ②④	—	—	—
Electrical Endurance	(Operation Cycles)	6000	6000	6000	6000	6000	1000	1000	500/1000⑤	500	
Mechanical Endurance	(Operation Cycles)	10,000	10,000	10,000	10,000	8000	6000	6000/ 5000 ⑤	3500/ 5000⑤	3500	
Shaft Size Square	Inches (mm)	.2 x .2 (5 x 5)	.4 x .4 (10 x 10)	.4 x .4 (10 x 10)	.4 x .4 (10 x 10)	.4 x .4 (10 x 10)	.59 x .59 (15 x 15)/ .4 x .4 (10 x 10) ③	.59 x .59 (15 x 15)	.59 x .59 (15 x 15)	.59 x .59 (15 x 15)	
Switch Operating Torque	lb. in.	21	88	88	88	106	320/132	320	320	320	
Terminal Lugs Wire Size Min- Max	Non-Fused	#14 – #10	#14 – #10	#10 – #3	#10 – #3	#6 – 3/0	(2)#2-(2) 600mcm	(2)#2-(2) 600mcm	(3)#2-(3) 600mcm	(3)#2-(3) 600mcm	
	Fusible	#14 – #10	#14 – #10	#10 – #3	#14 – 2/0	#6 – 3/0	(2)#2-(2) 600 mcm	(2)#2-(2) 600mcm	(3)#2-(3) 600 mcm	—	
Weight in Lbs. (kg)		1.1 (.50)	1.1 (.50)	2.0 (.91)	2.5 (1.1)	4.4 (2.0)	8.8 (4.0)	9.9 (4.5)	22.0 (10.0)	28.6 (13.0)	

① 2-pole in series.

② 3-pole in series.

③ 15 x 15 shaft for non-fusible and 10 x 10 shaft for fusible, 400A

④ DC rating on non-fusible 600A only, no DC rating for 600A fusible.

⑤ Values on left = non-fusible. Values on right = fusible.

Table 16. IEC Non-Fusible/Fusible Disconnect Switches from 32 to 1250 A

Description	Catalogue Number									
	C362UC30 C362UC30CT C363UC30JT	C363UV30C C363UV30J C363UV30CT C363UV30JT	C362UV60 C363UV60J C363UV60JT	C362UV100 C363UV100J C363UV100JT	C362UV200 C363UV200J C363UV200JT	C362US400 C363UV400J C363UV400JT	C362US600 C363UF600J	C362US800 C363UF800L	C362US1000	C362US1200
Rating Ampere	32	32	63	100	200	400	600/630 ①	800	1000	1250
Rated Insulation Voltage U _i (V)	800	750	750	750	750	1000	1000	1000	1000	1000
Rated Impulse Voltage (U _{imp})	8 kV	8 kV	8 kV	8 kV	8 kV	12 kV / 8 kV ①	12 kV	12 kV	12 kV	12 kV
Operation Current (A) 400 V AC – AC 22A – AC 23A	32 32	32 32	63 63	100 100	200 200	400 400	630 630	800 800	1000 1000	1200 1000
690 V AC – AC 22A – AC 23A	32 32	32 32	63 63	100 100	200 200	400 200/250 ①	500/630 ① 200/630 ①	630/800 ① 400/630 ①	630 400	630 400
Motor Power (kW)										
400 V AC – AC 23A	15	15	30	51	100	220	355	450	560	560
500 V AC – AC 23A	18.5	18.5	40	63	140	280	450	560	560	560
690 V AC – AC 23A	25	25	55	90	185	185/220 ①	185/600 ①	400/600 ①	400	400
Maxi. peak let through current (kA peak)	5.5	7.6	17.6	17.6/22 ①	32	48/36 ①	48/77 ①	75/77 ①	75	75
Connection										
Minimum Cu Cable Section (mm ²)	6	6	10	25	50	185	2 x 150	2 x 185 ③	2 x 240	—
Minimum Cu Busbar Section (mm ²)	—	—	—	—	—	—	2 x 30 x 5 ②	2 x 40 x 5	2 x 50 x 5	2 x 60 x 5

① Value on left = non-fusible/ value on right = fusible.

② Cable vs busbar connection on fusible @ 630A.

③ Busbar vs cable connection on fusible @ 800A.

Enclosed Rotary

- 30, 40, 60, 80 Ampere available.
- 600V, 3 pole, horsepower rated
- Type 12/3R, 4X Stainless and 4X Non Metallic Enclosures
- CSA approved to C22.2 #14 CEC rule 28-602(3) (b) manual motor controller suitable for motor disconnect
- Accepts auxiliary contacts
- Capability to signal PLC controller
- 10 kVA short circuit rating when used in conjunction with Class J fusing

Table 17. Rotary Disconnect Switches - Enclosed Switches

Ampere	Type 12/3R Enclosure ①	Type 4X Enclosure Stainless Steel	Type 4X Enclosure Non Metallic	Maximum Horsepower Ratings - Volts AC 1 phase AC					Maximum Horsepower Ratings - Volts AC 3 phase AC				
	Catalogue Number	Catalogue Number	Catalogue Number	120V	280V	240 V	480V	600V	120V	280V	220-240 V	440-480V	600V
Non-Fusible 3 Pole, 600V AC													
30	CDR3030UD	CDR3030UW	CDR3030UX	1.5	2	3	7.5	10	2	5	7.5	15	20
40	CDR3040UD	CDR3040UW	CDR3040UX	2	3	3	7.5	10	2	7.5	10	20	25
60	CDR3060UD	CDR3060UW	CDR3060UX	2	5	7.5	15	20	5	10	15	30	40
80	CDR3080UD	CDR3080UW	CDR3080UX	3	7.5	10	20	30	7.5	15	20	40	50
Auxiliary Contacts for Enclosed Rotary Switches													
30	CRAC3 ②	Auxiliary contact kit contains holder and 1 NO contact											
40	CRAC3 ②	Auxiliary contact kit contains holder and 1 NO contact											
60	CWAC3 ②	Auxiliary contact kit contains holder and 1 NO contact											
80	CWAC3 ②	Auxiliary contact kit contains holder and 1 NO contact											
Additional Auxiliary Contacts													
30 – 80	CRAB ②	1 NO contact											
30 – 80	CRAA ②	1 NC contact											

① Type 12 enclosure can be field modified to meet type 3R rainproof requirements when a factory provided drain hole is opened.

② The mechanism is reversed on these contacts.



CDR3040UX



CDR3030UD



CDR3060UD



CDR3030UW

CDR303UD CDR304UD

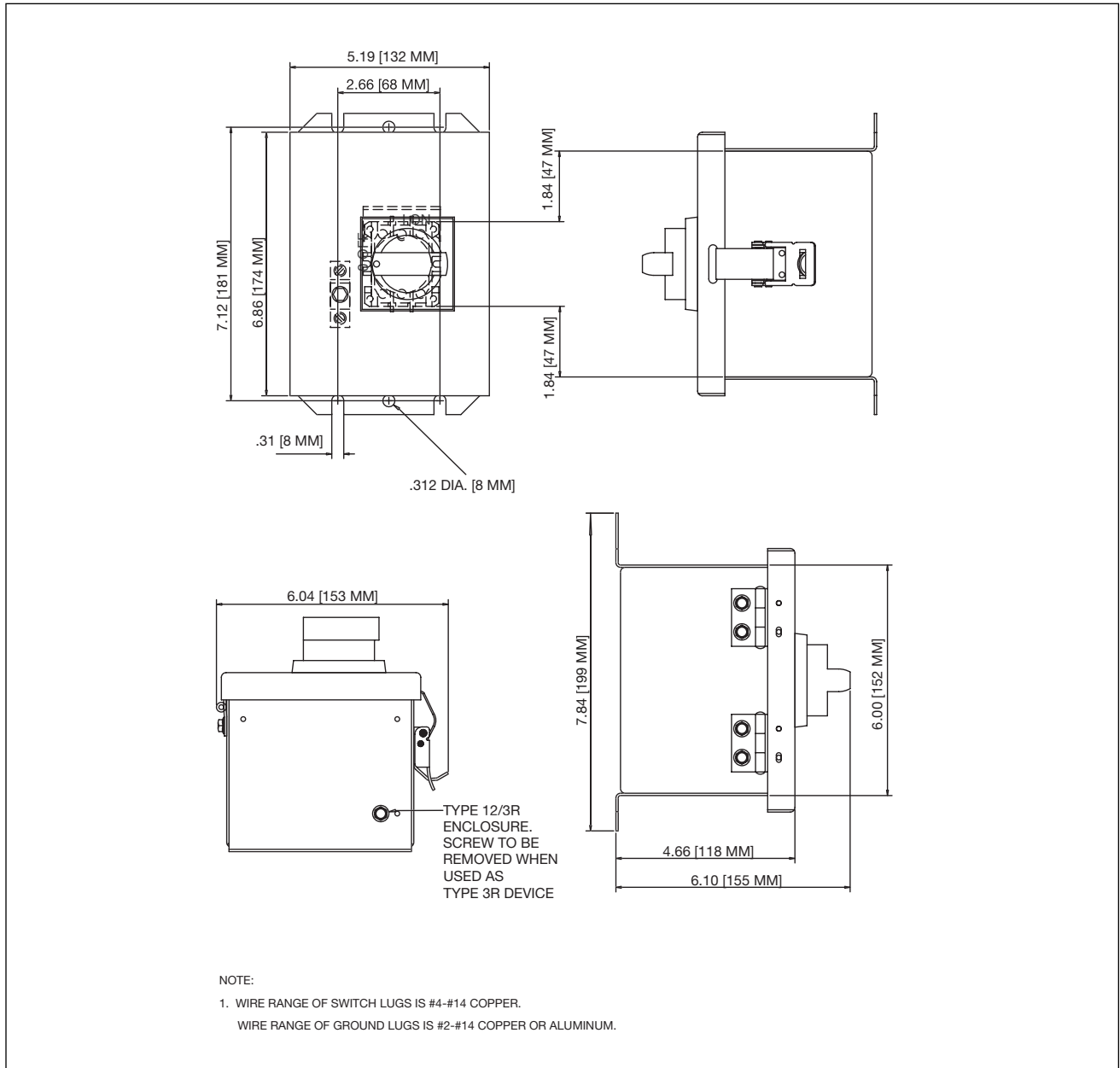

CDR306UD CDR380UD

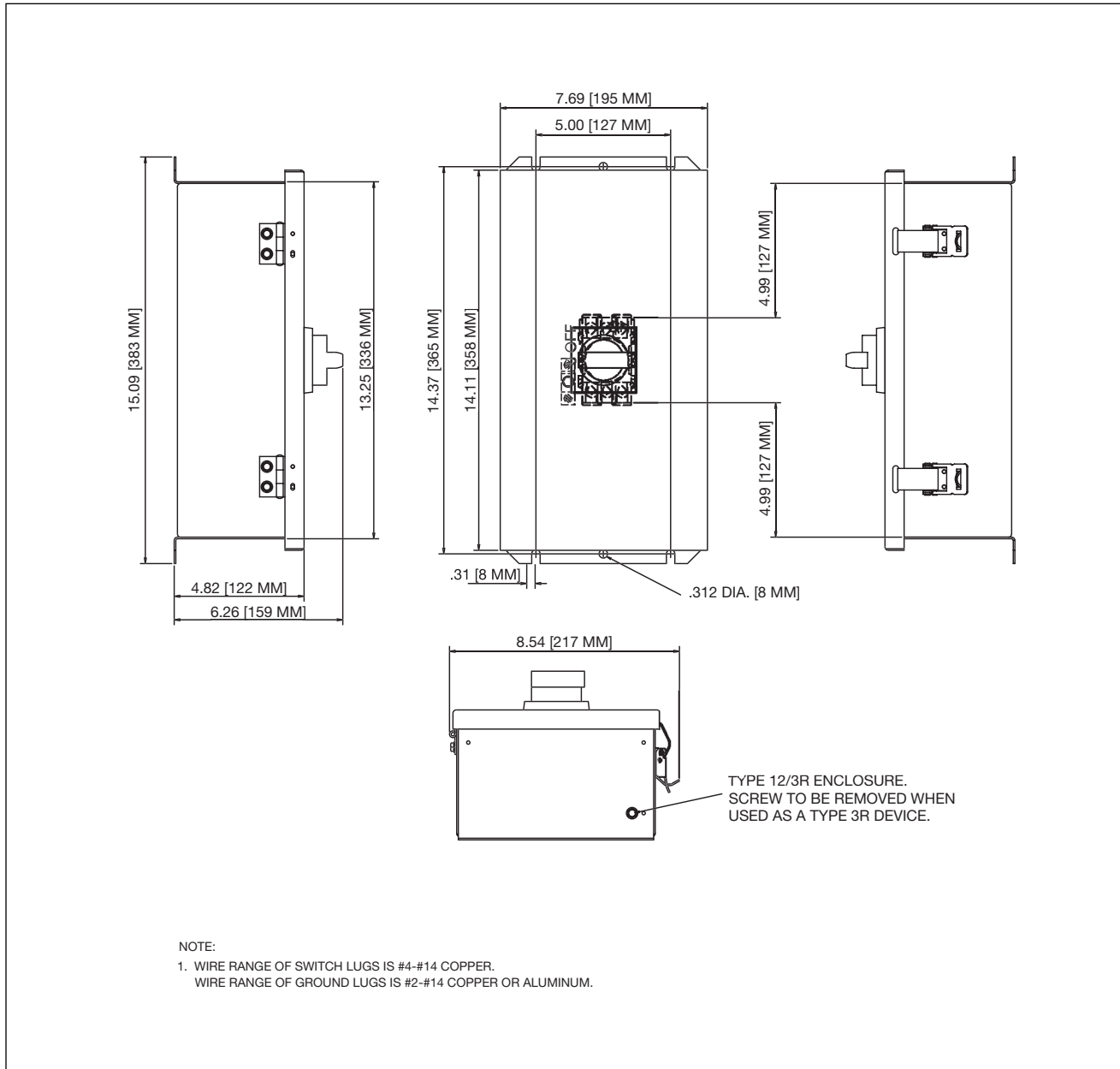

**CDR3030UW CDR3040UW
Type 4X Stainless Enclosure**

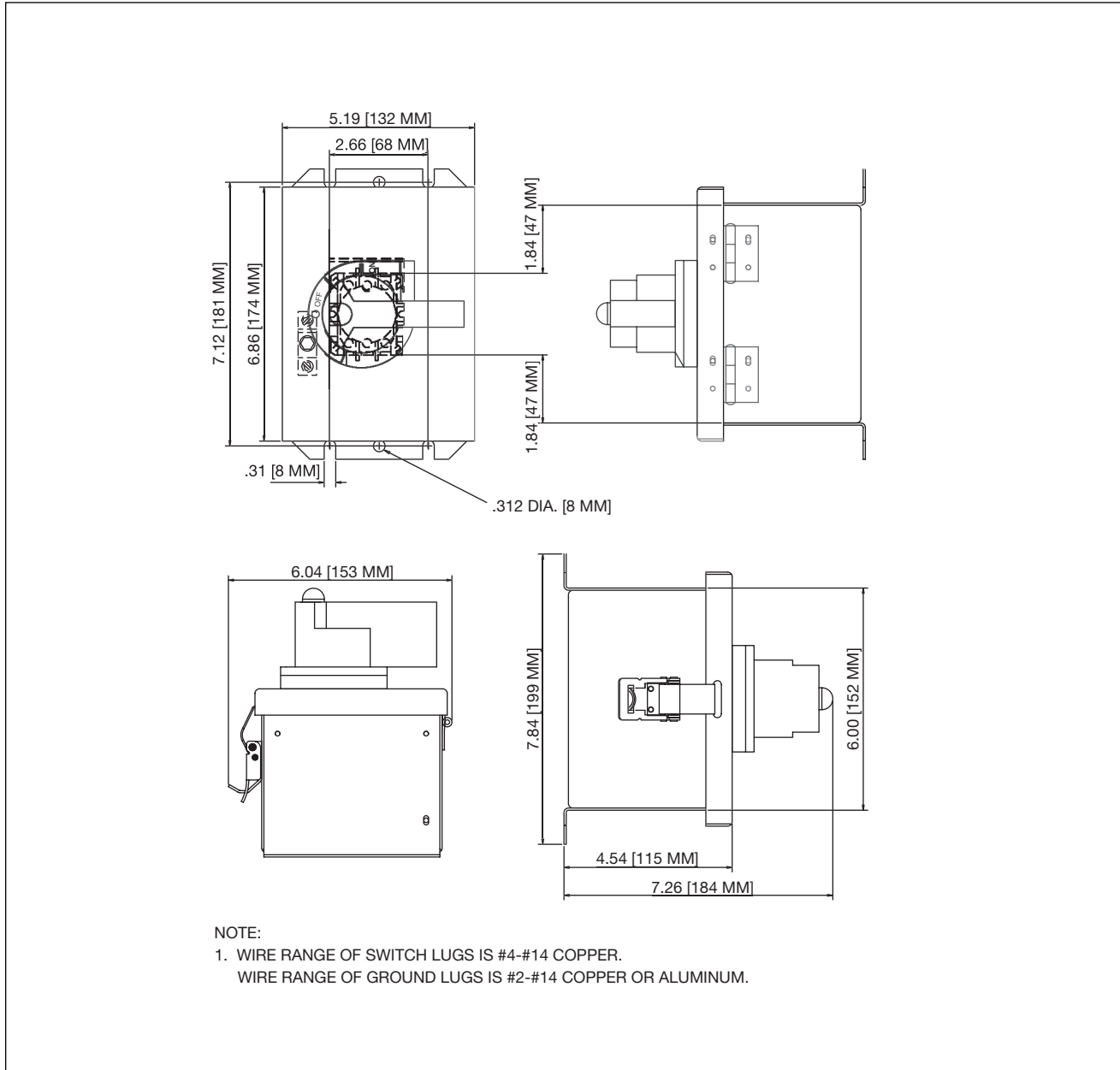

CDR3080UW CDR3060UW Type 4X Stainless Enclosure

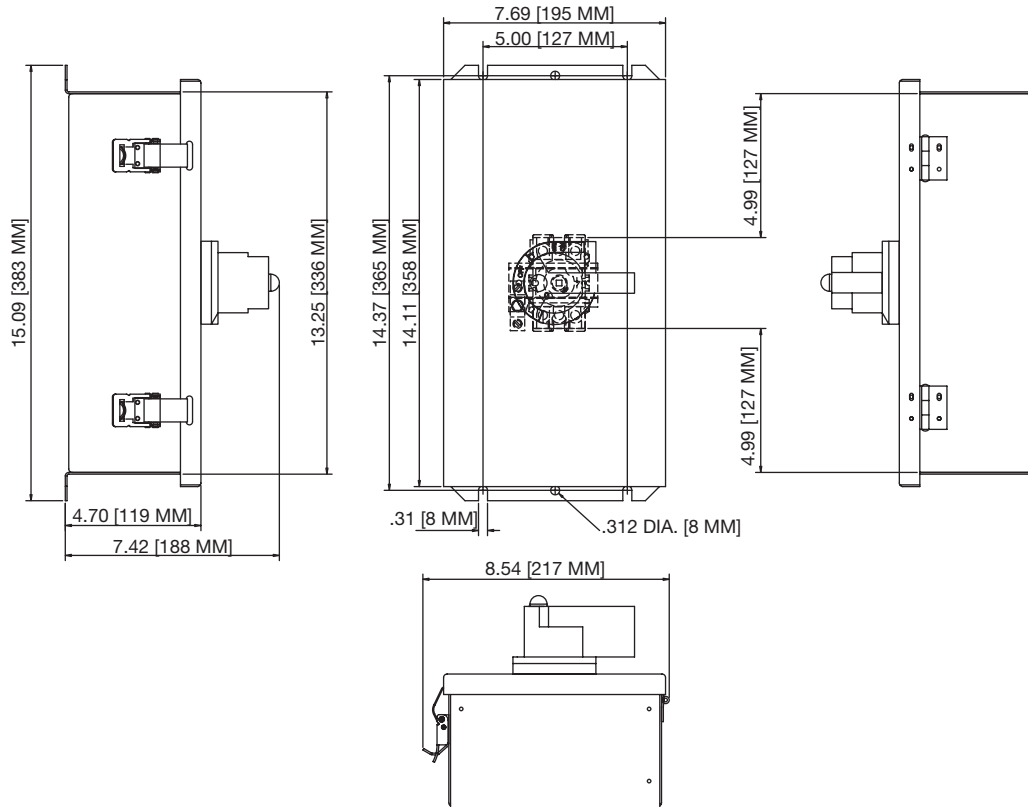

NOTE:

1. WIRE RANGE OF SWITCH LUGS IS #1-#14 COPPER.
WIRE RANGE OF GROUND LUGS IS #2-#14 COPPER OR ALUMINUM.

**CDR3040UX CDR3030UX
Type 4X Non-Metallic Enclosure**

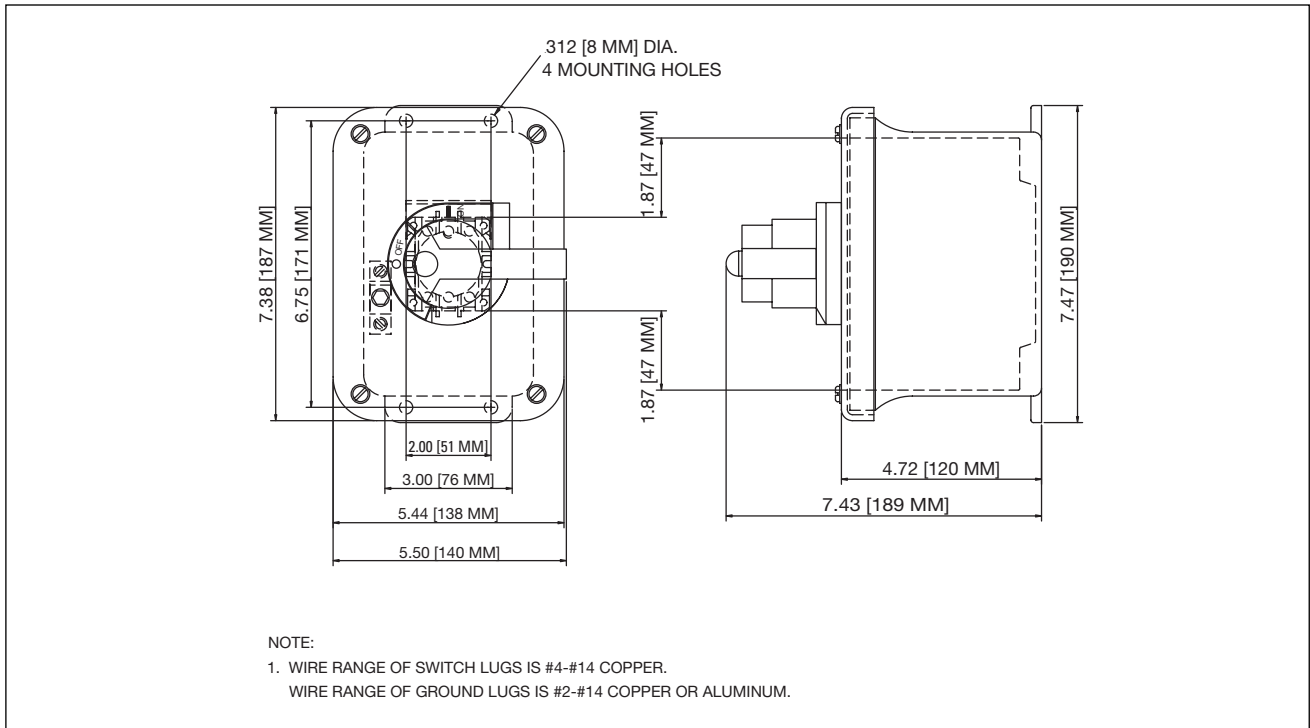

**CDR3060UX CDR3080UX
Type 4X Non-Metallic Enclosure**

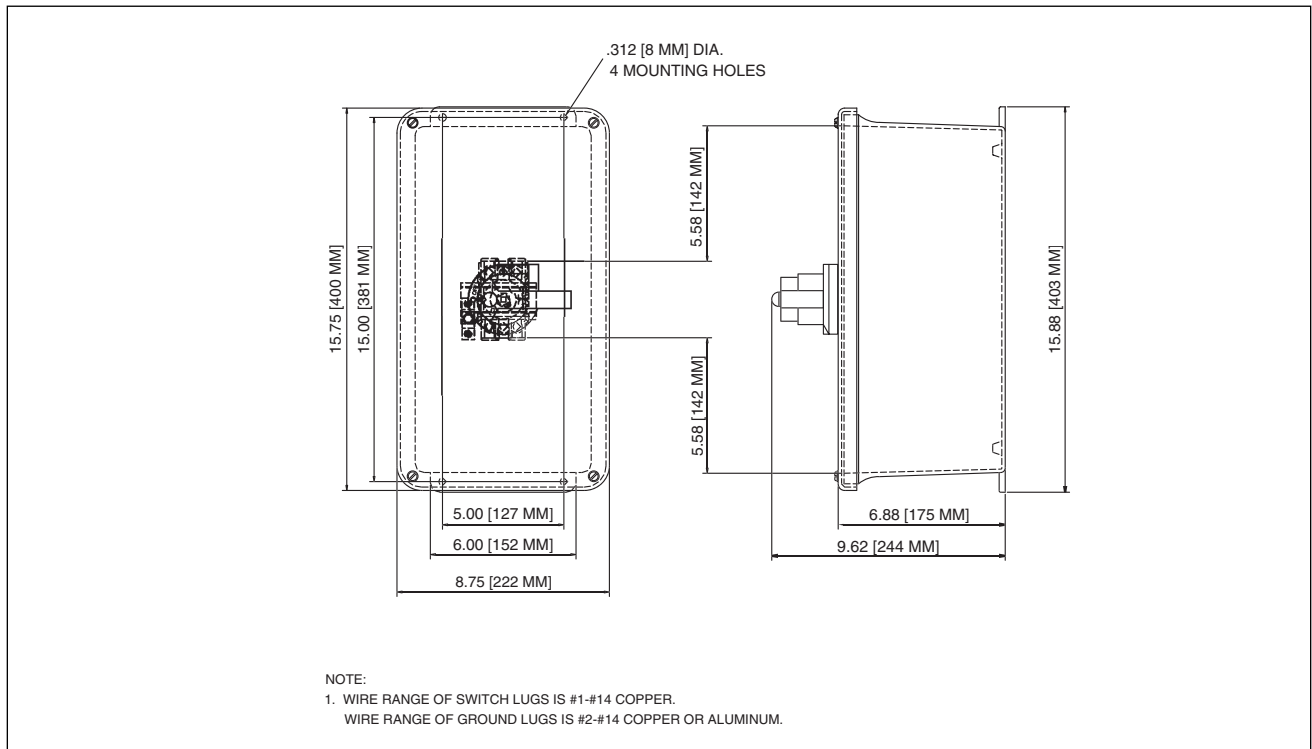

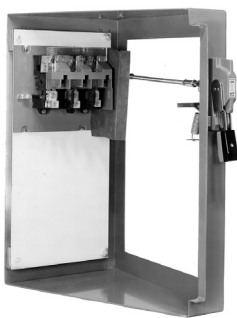

Complete Operating Mechanism — C361NE1



Handle Only — C361H1

Product Description

Type C361 Disconnect Switches are suitable for installation in control enclosures having a right-hand flange. Fusible disconnect switches will accept R fuses as standard. Field installable rejection kits are supplied as standard on 100A and 200A clips. For 30A and 60A rejection clips, see footnote ④. The switch is **CSA/UL** component recognized for use on systems with up to 200,000 rms symmetrical amperes available fault current when Class R clips are supplied. A standard connecting rod is supplied with switch.

Options and Accessories

Table 1. Electrical Interlocks

Circuit	Catalogue Number
1NO-1NC 2NO-2NC	DS200EK1 DS200EK2

Table 2. Connecting Rods — Increase Maximum Allowable Depth by 5 Inches

Application	Catalogue Number
Disconnect Switches 30, 60, 100 and 200A Circuit Breakers 150, 250 and 400A	C371CS1
Circuit Breakers 600, 800 and 1200A	C371CS2

Table 3. Operating Mechanism Variable Depth with Disconnect Switch — Right-Hand Mounting

Disconnect Switch Size (Amperes)	Variable Depth Mounting Range Minimum/Maximum (Inches) ①	Maximum Horsepower Ratings ②					Fuse Clip Rating (Amperes) Non-interchangeable Type for Class H, J, K or R Type Fuses Only		Switch and Operating Mechanism Only DOES NOT Include Handle	Switch and Operating Mechanism with 4-Inch Handle ③		
		AC System Volts (Motor Volts)				DC Using 2 Poles 250V Maximum	250V	600V		Catalogue Number	For NEMA 1 or 12 Enclosure	For NEMA 4 Enclosure
		208 (200)	240 (230)	480 (460)	600 (575)						Catalogue Number	Catalogue Number
30	7 to 16	7-1/2	7-1/2	15	20	5	Non-fusible		C361NC	C361NC1	C361NC2	
							30	—				C361SC21
60	7 to 16	15	15	30	50	10	Non-fusible		C361ND	C361ND1	C361ND2	
							60	30				C361SD22
100	7 to 16	25	30	60	75	20	Non-fusible		C361NE	C361NE1	C361NE2	
							100	100				C361SE263
200	7 to 16	40	60	125	150	40	Non-fusible		C361NF	C361NF1	C361NF2	
							200	200				C361SF264

① Dimension shown is from panel to flange surface.

② Refers to rating of switch only.

③ Components individually boxed and shipped in overpack carton.

④ For rejection clips, add Suffix Letter **R** to listed Catalogue Number, and add \$9. to price. Example: C361SC121R.

Table 4. Handle Only

Application	Operating Handle Length in Inches (mm)	NEMA Type Enclosure	Catalogue Number
For use with 30, 60, 100 and 200 Ampere Disconnect Switches	4.00 (101.6)	1-12	C361H1
	4.00 (101.6)	4	C361H2
	6.00 (152.4)	1-12	C361H3
	6.00 (152.4)	4	C361H4

Technical Data and Specifications

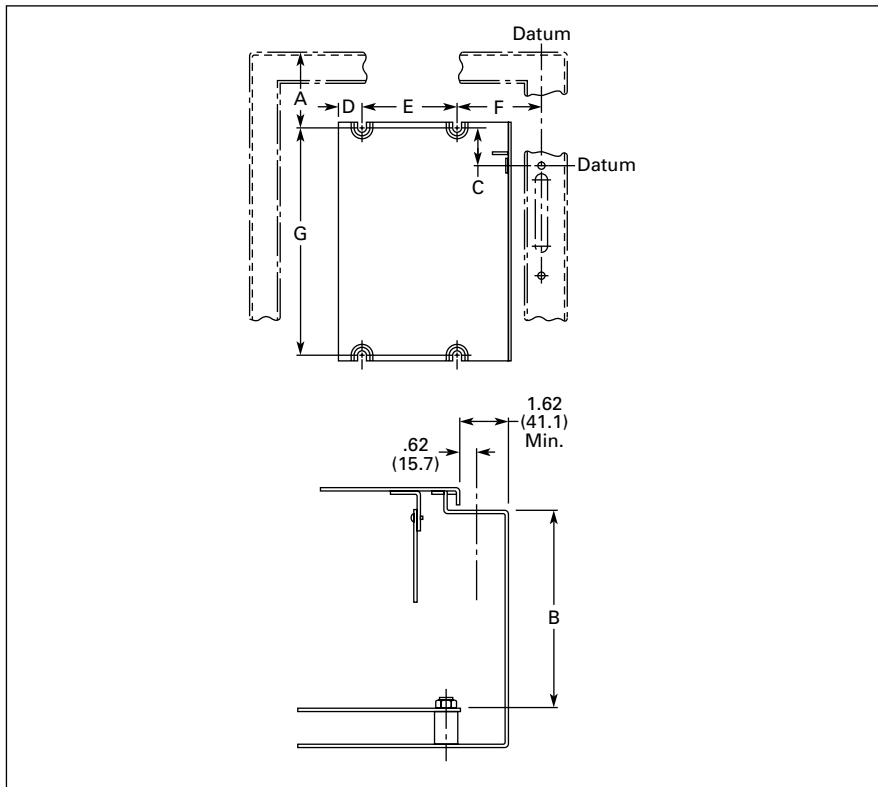

Figure 15. Mounting Dimension Requirements

Table 18. Mounting Dimension Requirements in Inches (mm)

Disconnect Switch Type	A	B	C	D	E	F	G
30A and 60A Non-fusible	See Dimensions Below	See Dimensions Below	1.56 (39.6)	.96 (24.4)	4.00 (101.6)	3.50 (88.9)	7.12 (180.8)
30A and 60A Fusible			1.56 (39.6)	.96 (24.4)	4.00 (101.6)	3.50 (88.9)	9.75 (247.7)
100A Non-fusible			1.75 (44.5)	1.10 (27.9)	5.50 (139.7)	3.38 (85.9)	7.12 (180.8)
100A Fusible			1.75 (44.5)	1.10 (27.9)	5.50 (139.7)	3.38 (85.9)	11.88 (301.8)
200A Non-fusible and Fusible			3.34 (84.8)	0.63 (16.0)	8.50 (215.9)	1.84 (46.7)	15.50 (393.7)

Table 19. Line Lug Data

Disconnect Switch Size	Wire Size
30 Ampere	#2 – 14 Cu/Al
60 Ampere	#2 – 14 Cu/Al
100 Ampere	1/0 – 14 Cu/Al
200 Ampere	250 kcmil – #6 Cu/Al

Dimension A = The required wire bending spacing selected from Article 430-10 of the National Electrical Code.

Dimension B = Minimum or maximum depth from inside of flange holding operating handle to panel where Disconnect Switch is mounted. (Variable 7 to 16 inches.)

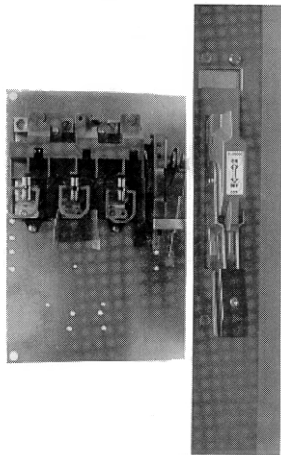

Product Description

Type C361 Disconnect Switches are suitable for installation in control enclosures having a right-hand flange. Fusible disconnect switches will accept R fuses as standard. Field installable rejection kits are supplied as standard on 100A and 200A clips. For 30A and 60A rejection clips, see footnote ②. The switch is **CSA/UL** component recognized for use on systems with up to 200,000 rms symmetrical amperes available fault current when Class R clips are supplied.

Fixed Depth – Flange to Panel

- 30-60A – 61/2 inches
- 100A – 7 inches

Table 23. Electrical Interlocks

Circuit	Catalogue Number
1NO-1NC 2NO-2NC	DS200EK1 DS200EK2

Table 24. Line Lug Data

Disconnect Switch Size	Wire Size
Disconnect Switches	
30 Ampere	#2 – 14 AL-CU
60 Ampere	#2 – 14 AL-CU
100 Ampere	#0 – 14 AL-CU
200 Ampere	250 MCM – #6 AL-CU

Table 25. Operating Mechanism Fixed Depth with Disconnect Switch — Right-Hand Mounting

Disconnect Switch Size (Amperes)	Maximum Horsepower Ratings ①					Fuse Clip Rating (Amperes) Non-interchangeable Type for Class H, J, K or R Type Fuses Only		Switch and Operating Mechanism with 4-Inch Handle For NEMA 1 or 12 Enclosure
	AC System Volts (Motor Volts)				DC Using 2 Poles 250V Maximum	250V	600V	
	208 (200)	240 (230)	480 (460)	600 (575)				Catalogue Number
30	7-1/2	7-1/2	15	20	5	Non-fusible		C361FNC1
						30	—	C361FSC121 ② C361FSC161 ②
60	15	15	30	50	10	Non-fusible		C361FND1
						60	30	C361FSD122 ② C361FSD162 ②
100	25	30	60	75	20	Non-fusible		C361FNE1
						100	100	C361FSE1263

① Refers to rating of switch only.

② For rejection clips, add Suffix Letter **R** to listed Catalogue Number. Example: C361FSC121R.

Table 26. Approximate Dimensions

Frame Size	Dimensions in Inches				
	A	B	C	D	E
30-60 Amp. Disc. Switch 150 Amp. Circ. Breaker	8-5/8	11-3/8	6-1/2	1-1/2	9-1/2
100 Amp. Disc. Switch 250 Amp. Circuit Breaker 400 Amp. Circuit Breaker	9-7/8	13-3/8	7	1-1/4	11-3/4

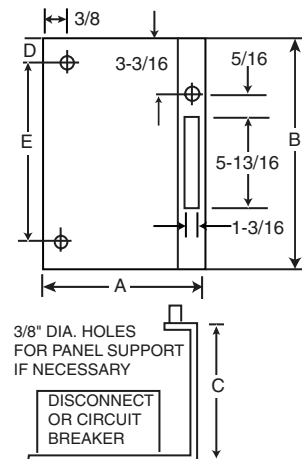

Fuse Clips for Variable or Flange Mount Operating Mechanisms



C351 Fuse Clip Kit

Table 27. C351 — Fuse Clip Selection — 3 Poles

Starter Size	Motor Voltage	Maximum Horsepower (3-Phase)	Fuse Clip Rating		Fuse Clip Kit for Field Installation with Non-fusible Starter			
			Amperes	Volts	Catalogue Number	Catalogue Number	Catalogue Number	Catalogue Number
					For Non-rejection Type Fuses	For use w/ "R" Rejection Type Fuses	For Form I Type "J" Fuses	For Form II Type "C" Fuses
0	200/230	3	30	250	C351KC21	C351KC21R	—	—
	460/575	5	30	600	C351KD22-61	C351KD22-61R	C351KD71	C351KD81
1	200/230	7-1/2	30	250	C351KC21	C351KC21R	—	—
	460/575		30	600	C351KD22-61	C351KD22-61R	C351KD71	C351KD81
2	200	10	60	250	C351KD22-61	C351KD22-61R	—	—
	230	15	60	250	C351KD22-61	C351KD22-61R	—	—
	460/575	25	60	600	C351KD62	C351KD62R	C351KD72	C351KD82
3	200	25	100	250	C351KE23-63 ①	C351KE23-63 ①	—	—
	230	30	100	250	C351KE23-63 ①	C351KE23-63 ①	—	—
	460/575	50	100	600	C351KE23-63 ①	C351KE23-63 ①	C351KE73	C351KE83
4	200	40	200	250	C351KF24-64 ①	C351KF24-64 ①	—	—
	230	50	200	250	C351KF24-64 ①	C351KF24-64 ①	—	—
	460/575	100	200	600	C351KF24-64 ①	C351KF24-64 ①	C351KF74	C351KF84
5	200	75	400	250	Not Available in Kit Form	Not Available in Kit Form	Not Available in Kit Form	Not Available in Kit Form
	230	100	400	250				
	460/575	200	400	600				

① Fuse clip "R" rejection members for use with Class R fuses are supplied loose in the Fuse Clip Kits.

Note: Kits do not include fuses.



NEMA 12 Safety Door Hardware

Product Selection

Type C361 NEMA 12 Safety Door Hardware

Type C361 Door Hardware Kits are designed to function with all C361 and C371 disconnect switches and circuit breaker operating mechanisms.

These kits are designed for use with small enclosures up to 40 inches (1016 mm), intermediate 40 – 60 inches (1016 – 1524 mm) or larger floor cases over 60 inches (1524 mm) to provide enclosure sealing and protection against unauthorized entry. These kits can be used on enclosure flanges with material thickness ranging from 16 gauge through 3/16 inches with flanges on the right side only. Door hardware kits are to be installed in a commercially available enclosure. Consult the enclosure manufacturer application data for proper kit selection.

Table 28. Type C361 NEMA 12 Safety Door Hardware

Handle Length (Inches)	Catalogue Number ①
4	C361KJ4
6	C361KJ6
Roller Latch ②	C361KR

① The 1/4-inch x 1/2-inch standard mill rectangular locking bar is not supplied with these kits.

② Third roller latch for use with 4 or 6-inch handle when 3 point latching is required.

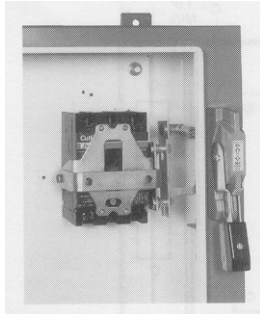

Complete Circuit Breaker Operating Mechanism with Operating Handle – C371E1



Handle Only – C371H1

Product Description

Type C371 Circuit Breaker Operating Mechanisms are designed for installation in control enclosures where main or branch circuit protective devices are required. All circuit breaker mechanisms are suitable for right hand mounting. Auxiliary contacts are not available for mounting on operating mechanism. Where required, have them installed in circuit breaker.

Table 29. Operating Mechanisms for Circuit Breakers — Flange Mounted Variable Depth

Circuit Breaker or Motor Circuit Protector	Frame Size	Variable Depth Mounting Range Min./Max. (Inches) ① ②	Operating Mechanism Only – Does Not Include Handle	Operating Mechanism With 4 Inch Handle & Rod	
				For NEMA 1-12 Enclosure	For NEMA 4 Enclosure
			Catalogue Number	Catalogue Number	Catalogue Number
HMCP, EHD, FDB, FD, FDC, HFD	150	6-1/2 to 16	C371E	C371E1	C371E2
HMCP, HJD, JD, JDB, JDC HMCP, DK, HKD, KD, KDB	250 400	6-1/2 to 16-5/8	C371F	C371F5	C371F6
HLD, LD, LDC	600	8-1/2 to 22	C371G	C371G5	C371G6
MD, MDS HND, ND, NDC	800 1200	8-3/4 to 22 9-3/4 to 22	C371K	C371K5	C371K6

① For increased maximum allowable depth, see Connecting Rods below.
② Dimensions shown are from panel flange surface.

Table 30. Handle Only

Circuit Breaker Frame Size (Amperes)	NEMA Enclosure Type	Operating Handle Length	Catalogue Number
150	1-3R-3-12 4	4 Inches 4 Inches	C371H1 C371H2
	1-3R-3-12 4	6 Inches 6 Inches	C371H3 C371H4
250 thru 1200	1-3R-3-12 4	4 Inches 4 Inches	C371H5 C371H6
	1-3R-3-12 4	6 Inches 6 Inches	C371H7 C371H8

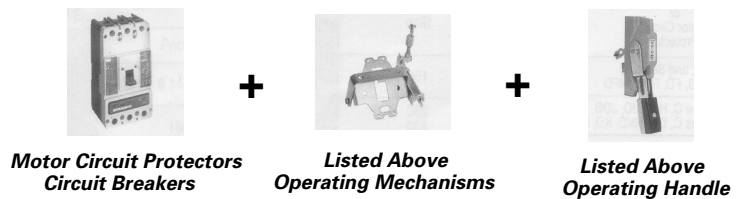

**Channel Support Kit –
Rod not supplied in Kit**

For use to prevent bending of the operating handle mounting surface. This is especially useful when the operating handle is mounted on a channel in a multi-door enclosure. Kit included in 600 through 1200 ampere mechanisms. **Catalogue Number C371CS6**

Table 31. Connecting Rods
Increase Maximum Allowable Depth by 5 Inches

Application	Catalogue Number
Disconnect Switches 30 , 60, 100, 200 Ampere Circuit Breakers 150, 250, 400 Ampere	C371CS1
Circuit Breakers 600, 800, 1200 Ampere	C371CS2

For Safety Door Hardware – see Page 27

Mounting Dimension Requirements

Dimension A = 0.75 in. plus the required wire bending spacing selected from Article 430-10 of the National Electrical Code.

Dimension B = Minimum or maximum depth from inside of flange holding operating handle to panel where Circuit Breaker is mounted.
(variable depth, see page 22)

Dimension C = 150 Ampere Size – 0.67 in.
250 Ampere Size – 0.625 in.
400 Ampere Size – 0.187 in.
600 Ampere Size – 1.71 in.
800 – 1200 Ampere Size – 5.17 in.8

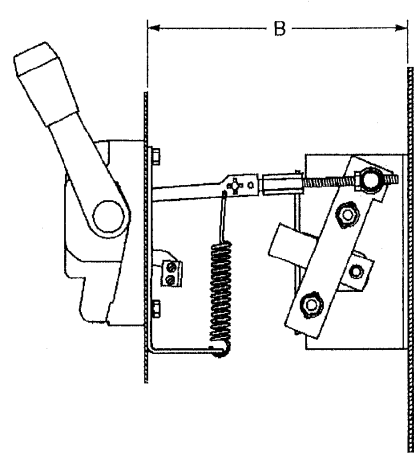
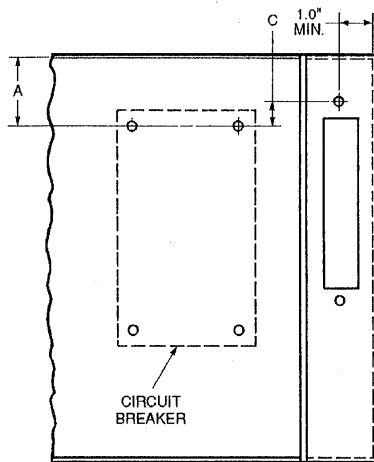

Technical Data and Specifications

Product Description

Type C371 Circuit Breaker Operating Mechanisms are designed for installation in control enclosures with a right hand flange and where main or branch circuit protective devices are required.

Auxiliary contacts are not available for mounting on operating mechanism. Where required, have them installed in circuit breaker.

Table 32. Flange Mounted Fixed Depth Operating Mechanisms for Circuit Breaker

Circuit or Motor Circuit Protector	Frame Size	Variable Depth Mounting Range Min./Max. (Inches)	Operating Mechanism With 4 Inch Handle For NEMA 1 or 12 Enclosure
			Catalogue Number
HMCP, EHD, FDB, FD, FDC, HFD	150	6-1/2	C371FE1
HMCP, HJD, JD, JDB, JDC HMCP, DK, HKD, KD, KDB	250 400	7	C371FF1

Eaton Electrical Inc. is a global leader in electrical control, power distribution and industrial automation products and services. Through advanced product development, world-class manufacturing methods, and global engineering services and support, Eaton Electrical® provides customer-driven solutions under brand names such as Cutler-Hammer®, Durant®, Heinemann®, Hol and MEM®, which globally serve the changing needs of the industrial, utility, light commercial, residential, and OEM markets. For more information, visit www.eatonelectrical.ca.

Eaton Corporation is a diversified industrial manufacturer with 2003 sales of \$8.1 billion. Eaton is a global leader in fluid power systems and services for industrial, mobile and aircraft equipment; electrical systems and components for power quality, distribution and control; automotive engine air management systems, powertrain solutions and specialty controls for performance, fuel economy and safety; and intelligent truck drivetrain systems for safety and fuel economy. Eaton has 55,000 employees and sells products to customers in more than 100 countries. For more information, visit www.eaton.com.

Eaton Corporation
3228 South Service Road
Burlington, ON L7N 3H8
Canada
1-800-268-8378
www.eatonelectrical.ca

EATON

Cutler-Hammer

© 2004 Eaton Corporation
All Rights Reserved
Pub. No.PG.35G.02.T.K
December 2004
Printed in Canada